

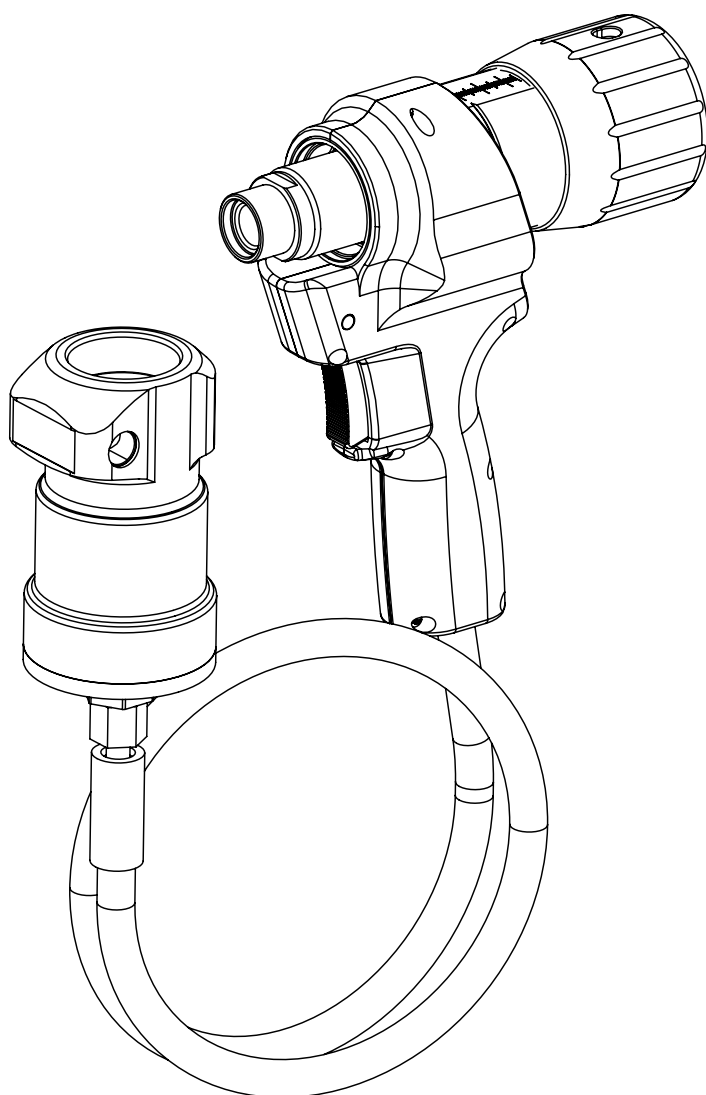

Notice Originale



 Video

FR 02-15 / 68

EN 16-28 / 68

ES 29-41 / 68

IT 42-54 / 68

NL 55-67 / 68

Adaptateur rivets aveugles 50kN pour riveteuse 10T
50kn blind rivet adapter for 10T riveter
Adaptador remaches ciegos 50kN para remachadora 10T
Adattatore rivetti ciechi 50kN per rivettatrice 10T
Adapter blindklinknagels 50 kN voor ponsnageltang 10T

DESCRIPTION

L'adaptateur pour rivets aveugles est compatible avec les riveteuses GYSPRESS 8T/10T et GYSPRESS 8T PUSH PULL. Sa force de rivetage est de 50 kN. Il permet de poser des rivets aveugles de diamètre 4.0 à 7.8 mm pour l'aluminium et de 4.0 à 6.4 mm pour l'acier ainsi que des écrous et goujons a sertir.

CONSIGNES DE SÉCURITÉ

- L'adaptateur 50KN ne doit pas servir à faire autre chose que poser des rivets aveugles ainsi que des écrous et goujons a sertir.
- Port obligatoire : lunettes de protection, protection anti-bruit, gants de sécurité. Ne jamais diriger le nez de l'outil vers soi ou vers quelqu'un d'autre.
- Utiliser obligatoirement des rivets de pose aveugle suivant les spécifications.
- Monter l'embout en fonction de la taille du rivet. Ne jamais forcer pour placer la queue de rivet dans l'embout. Ne jamais utiliser un embout plus large que la queue de rivet.
- Vérifier que le bridage de la pièce à riveter soit correct.
- Maintenir fermement la riveteuse jusqu'à ce que la coupure de la queue de rivet soit achevée et éjectée. Dans le cas contraire relâcher la gâchette puis reprendre la traction en appuyant de nouveau sur la gâchette,
- Débrancher systématiquement la machine après chaque utilisation et changement d'embout de rivetage.
- Conserver précieusement ce manuel d'utilisation. En cas de perte, contactez-nous.

ENVIRONNEMENT

Ce matériel doit être utilisé uniquement pour faire des opérations de rivetage dans les limites indiquées par la plaque signalétique et/ou le manuel. Il faut respecter les directives relatives à la sécurité. En cas d'utilisation inadéquate ou dangereuse, le fabricant ne pourra être tenu responsable.

L'installation doit être utilisée dans un local sans poussière, ni acide, ni gaz inflammable ou autres substances corrosives de même pour son stockage. S'assurer d'une circulation d'air lors de l'utilisation.

Plages de température :

Utilisation entre -10 et +40°C (+14 et +104°F).

Stockage entre -20 et +55°C (-4 et 131°F).

Humidité de l'air :

Inférieur ou égal à 50% à 40°C (104°F).

Inférieur ou égal à 90% à 20°C (68°F).

Altitude :

Jusqu'à 1000 m au-dessus du niveau de la mer (3280 pieds).

EN CAS DE PANNE**L'opération de rivetage ne s'effectue pas :**

- Vérifier si l'écrou de réglage de course est bien réglé à la bonne valeur.
- Vérifier si la riveteuse utilisée fonctionne correctement.
- Vérifier si il n'y a pas de fuites d'huiles ou d'air comprimé.

CONSIGNES DE MAINTENANCE

- Conserver l'outil en bon état de propreté. Vérifier périodiquement le bon état des raccords d'air comprimé, le bon fonctionnement de l'adaptateur 50 kN (le jeu naturel entre la queue de rivet et l'embout).
- En cas de fuite d'huile, enlever de la riveteuse et retourner l'appareil.
- Remplacement des mors (voir p.6)

RÉCAPITULATIF

Riveteuses	Puissance
GYSPRESS 8T	40 kN
GYSPRESS 8T PP	40 kN
GYSPRESS 10T	50 kN
GYSPRESS 10T PP	50 kN
GYSPRESS 10T Connect	50 kN

MONTAGE SUR GYSPRESS

GYSPRESS 8T :

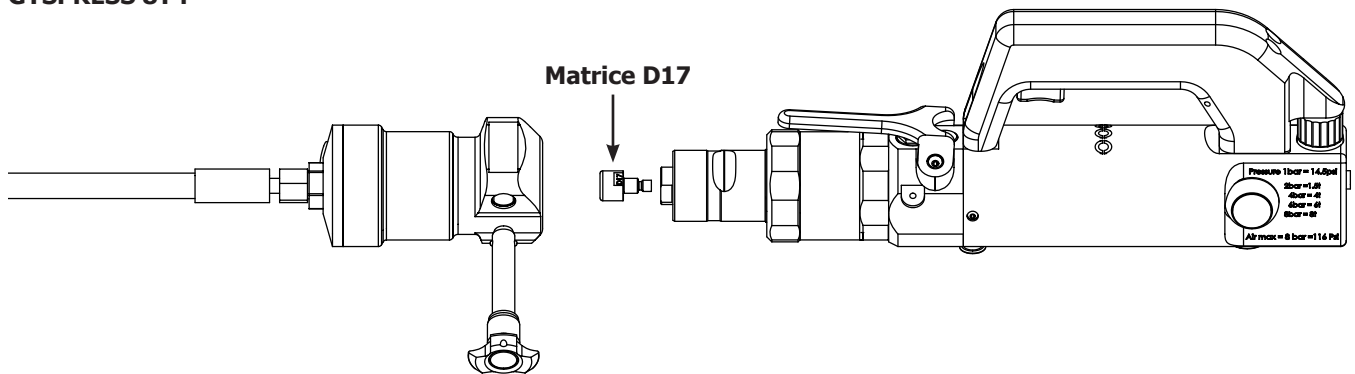

GYSPRESS 8T PP :

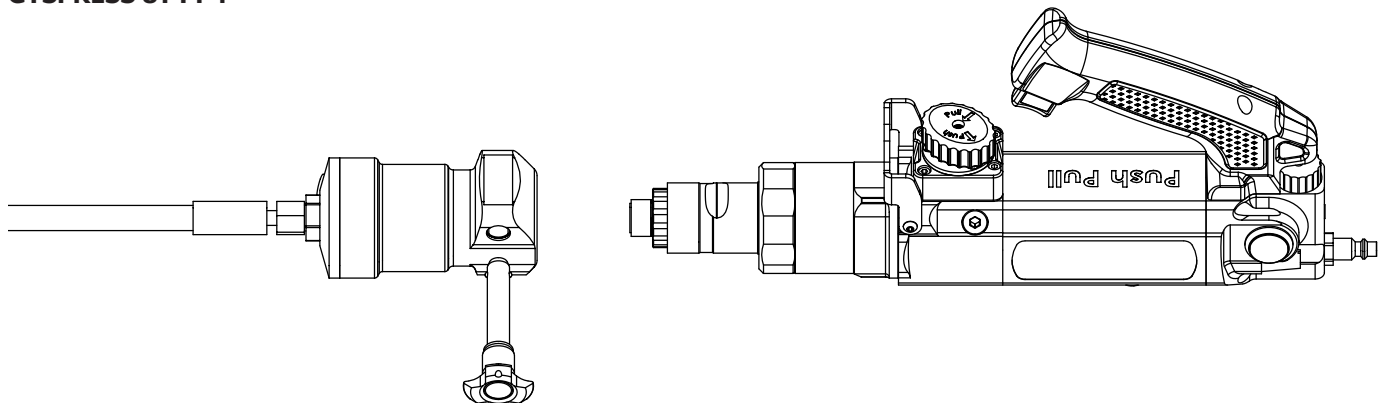

GYSPRESS 10T :

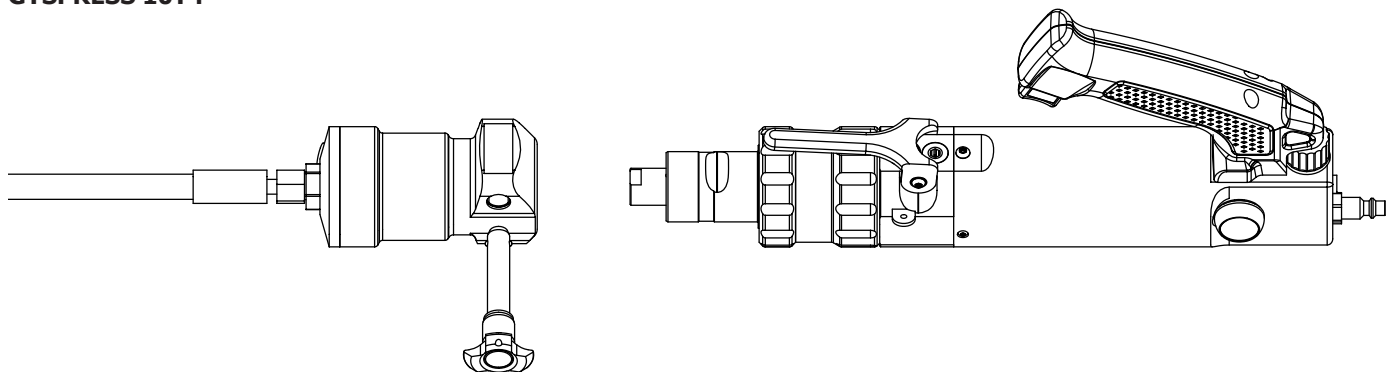

GYSPRESS 10T Connect :

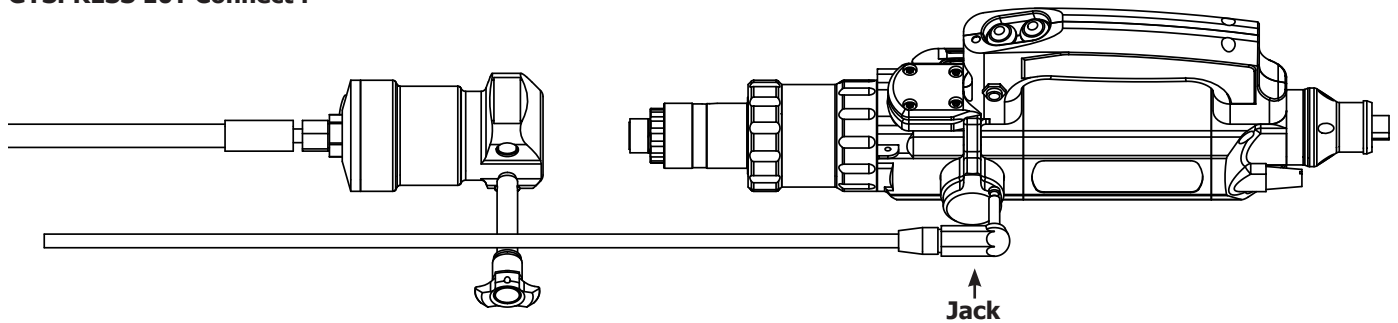

REGLAGES DE L'EFFORT DE L'ADAPTATEUR

L'effort de traction de l'adaptateur dépend de l'effort émis par la riveteuse :

Tableau de correspondance avec l'effort fournit par la riveteuse et de la pression d'air en entrée de la riveteuse.

Pression d'air	2 bar / 29 Psi		3 bar / 44 Psi		4 bar / 58 Psi		5 bar / 72 Psi		6 bar / 87 Psi		6,5 bar / 94 Psi		7 bar / 101 Psi		8 bar / 116 Psi	
	Riveteuse	Adaptateur	Riveteuse	Adaptateur	Riveteuse	Adaptateur	Riveteuse	Adaptateur	Riveteuse	Adaptateur	Riveteuse	Adaptateur	Riveteuse	Adaptateur	Riveteuse	Adaptateur
GYPESPRESS 8T	20 kN	10 kN	30 kN	15 kN	40 kN	20 kN	50 kN	25 kN	60 kN	30 kN	65 kN	32,5 kN	70 kN	35 kN	80 kN	40 kN
GYPESPRESS 8T PP	20 kN	10 kN	30 kN	15 kN	40 kN	20 kN	50 kN	25 kN	60 kN	30 kN	65 kN	32,5 kN	70 kN	35 kN	80 kN	40 kN
GYPESPRESS 10T	29 kN	19,5 kN	44 kN	22 kN	58 kN	29 kN	72 kN	36 kN	87 kN	43,5 kN	100 kN	50 kN	100 kN	50 kN	100 kN	50 kN
GYPESPRESS 10T PP	29 kN	19,5 kN	44 kN	22 kN	58 kN	29 kN	72 kN	36 kN	87 kN	43,5 kN	100 kN	50 kN	100 kN	50 kN	100 kN	50 kN
GYPESPRESS 10T Connect	29 kN	19,5 kN	44 kN	22 kN	58 kN	29 kN	72 kN	36 kN	87 kN	43,5 kN	100 kN	50 kN	100 kN	50 kN	100 kN	50 kN

REGLAGES DE LA COURSE

La course de l'adaptateur est réglable de 0 à 25 mm.
Elle se fait par l'intermédiaire de la molette A.
Visser à fond pour avoir 0 de course.
Dévisser à fond pour avoir 25 mm de course.

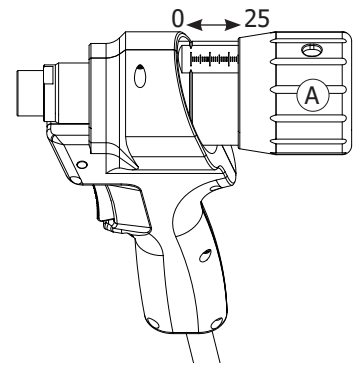

DIFFÉRENTS KITS SUR ADAPTATEUR

Kit 1 :
Pose de rivets aveugles pour diamètre de tige jusqu'à 5 mm + extraction de rivet auto-poinçonneur.

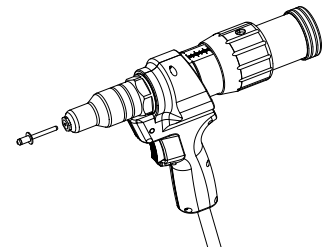

Kit 2 :
Pose d'écrous et de goujons à sertir M5 à M14.

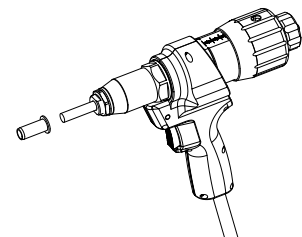

Kit 3 :
Rallonge pour pose de rivets aveugles pour diamètre de tige jusqu'à 5mm + extraction de rivet auto-poinçonneur.

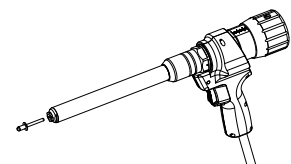

Kit 4 :
Pose de rivets aveugles ø 9.8 mm.

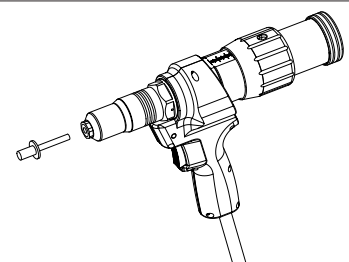

KIT 1

POSE DE RIVETS AVEUGLES POUR DIAMETRE DE TIGE JUSQU'À 5MM + EXTRACTION DE RIVET AUTO-POINÇONNEUR.

Ordre de montage du kit 1 :

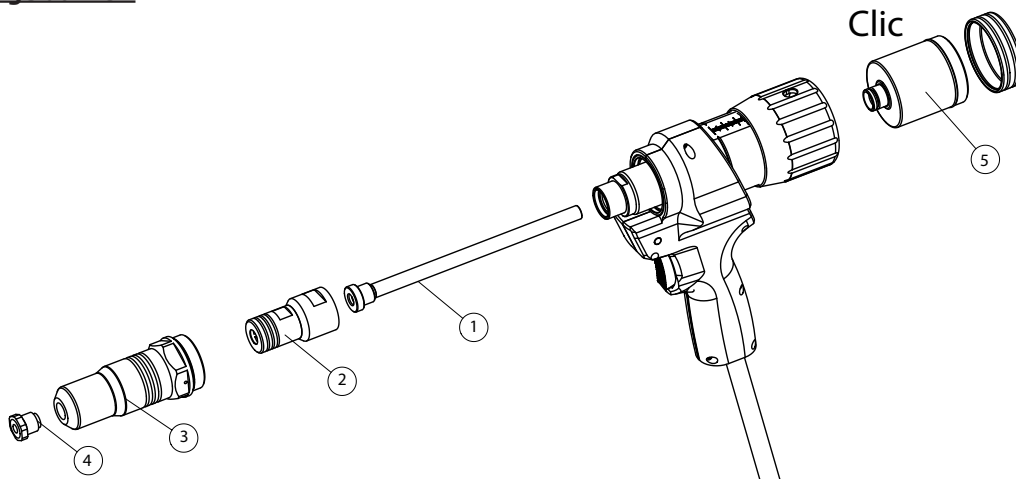

- 1- Mettre la tuyère 1
- 2- Visser le support de mors 2 avec les 2 clés de serrage (bien serrer)
- 3- Visser le support de buse 3 avec les 2 clés de serrage
- 4- Visser l'une de buse adaptée au rivet à poser :

- Ø3.2 ref : 065994
- Ø3.5 ref : 066007
- Ø4.0 ref : 066014
- Ø4.5 ref : 066021
- Ø5.0 ref : 066038

Pour faciliter la mise en place des buses :

- 1- Positionner un rivet dans la buse.
- 2- Insérer le rivet avec la buse dans le support monté.
- 3- Serrer la buse avec clé de serrage.

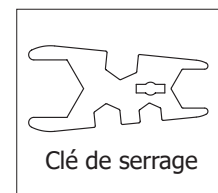

- 5- Enfiler le bol de récupération

Pose d'un rivet aveugle :

Après avoir monté la buse adéquate, placer le rivet jusqu'en butée de la buse

Placer le rivet à travers le trou des tôles à riveter et appuyer sur la gâchette de la riveteuse suivant le modèle ci-dessous :

GYPRESS 8T	GYPRESS 8T PP	GYPRESS 10T	GYPRESS 10T PP	GYPRESS 10T Connect

Une fois le rivet claqué posé, lâchez la gâchette . Pour les riveteuses 8T et 10 T appuyer sur la gâchette ci-dessous.

GYPRESS 8T	GYPRESS 10T

En penchant l'adaptateur en arrière, les tiges des rivets tombent dans le bol de récupération.
En penchant vers l'avant, les tiges sortent par la buse.

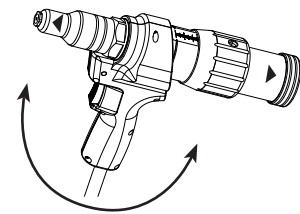

Récupération des tiges :

Pour récupérer les tiges, tirez sur le couvercle du bol.
Une fois les tiges récupérées remettre le couvercle jusqu'au clic.

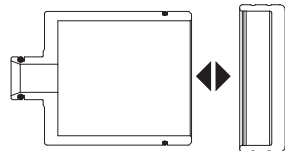

- | | |
|------------------|-------|
| 1- Bol | M0077 |
| 2- Couvercle | M0078 |
| 3- Joint torique | 55262 |
| 4- Joint torique | 55121 |

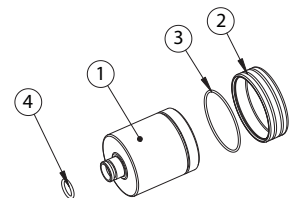

Remplacement des mors :

Dévisser a l'aide des clés de serrage.
Remplacer les mors 2 puis, les positionner dans 3 à 120°.
Placer 4 puis 5 et ensuite visser 1 a l'aide des clés (bien serrer).



Clé de serrage

- | | |
|-----------------------|-------|
| 1- Liaison cône mors | M0042 |
| 2- Mors (réf. 058446) | 51522 |
| 3- Cône mors | M0043 |
| 4- Écarteur | M0044 |
| 5- Ressort | 55189 |

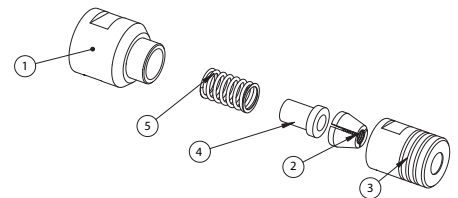

Extraction de rivets auto poinçonneur :

Le kit peut recevoir une buse spéciale pour l'extraction des rivets auto-poinçonneur via la soudure d'une tige sur le rivet (ref. 066151).

Montage de la buse :

Monter la buse d'extraction 066151 sur le support de buse.

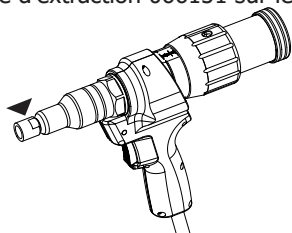

Régler l'écrou de réglage de course sur 15 mm.

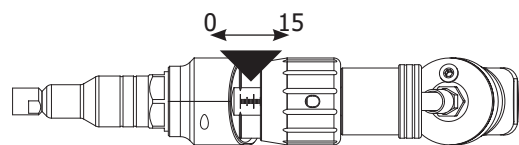

Étapes d'extraction :

1- Soudure de la tige d'extraction :
Matériel : ARC PULL 350 062191 + ARC PULL RIVET BOX 064584

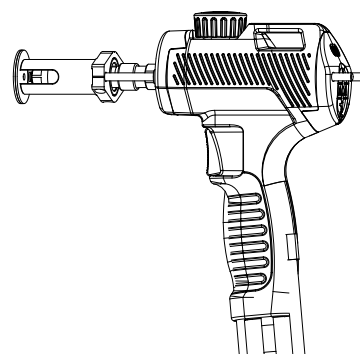
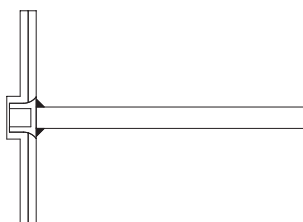

2- Insérer la tige d'extraction du rivet jusqu'au bout dans le pistolet, la buse en contact avec la tôle :

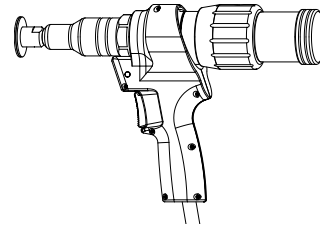
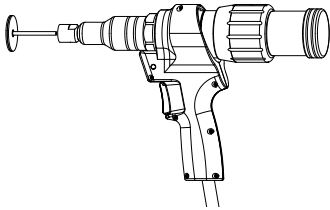

3- Actionner l'adaptateur suivant les modèles ci-dessous :

GYPRESS 8T	GYPRESS 8T PP	GYPRESS 10T	GYPRESS 10T PP	GYPRESS 10T Connect

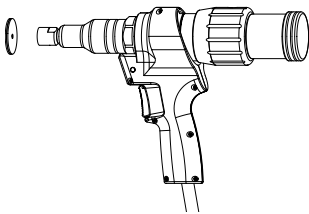

Une fois le rivet extrait de la tôle, relâcher la gâchette. Pour les riveteuses 8T et 10T, appuyez sur la gâchette ci-dessous :

GYPRESS 8T	GYPRESS 10T

Le rivet et la tige ressortent sur l'avant :

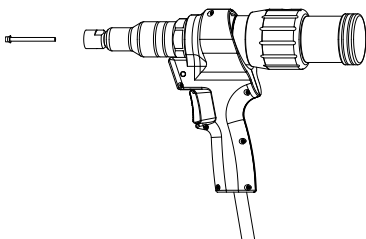

KIT 2

POSE D'ÉCROUS ET DE GOUJONS A SERTIR M5 À M14.

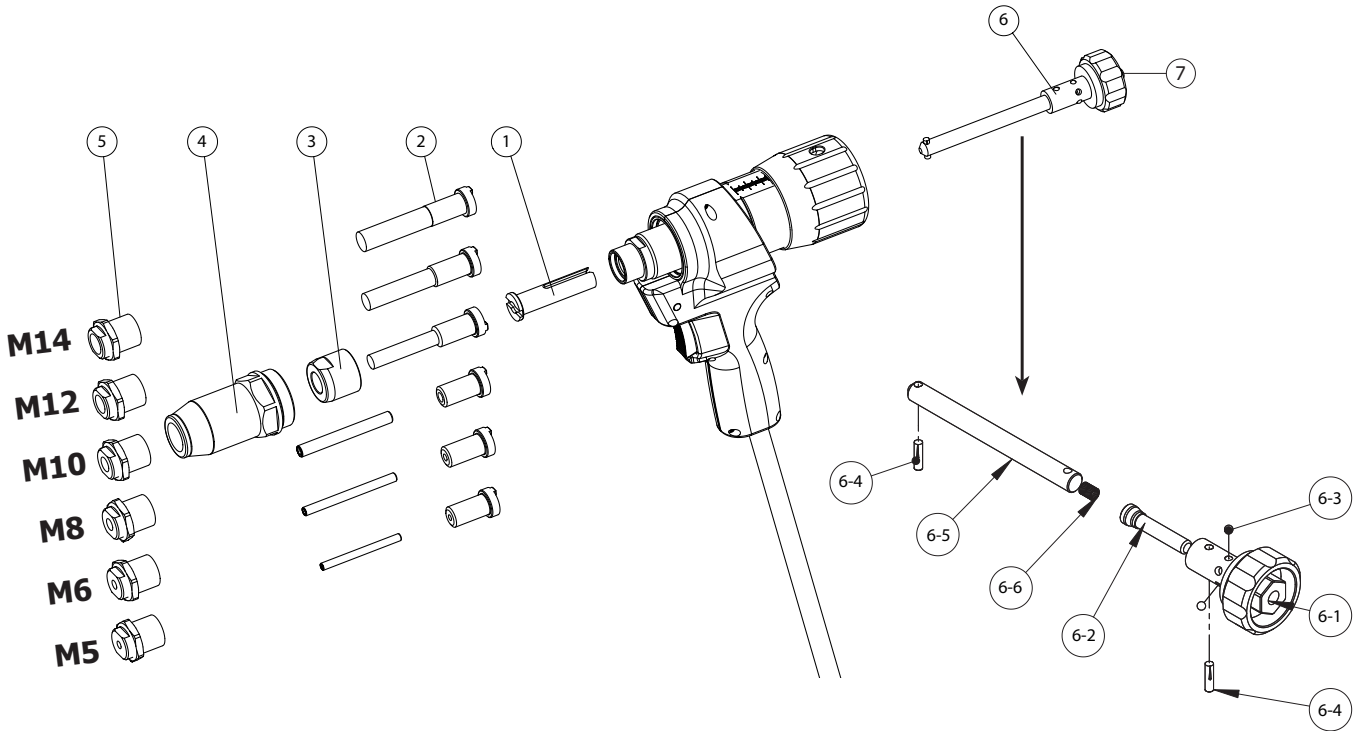

Ordre de montage du kit 2 :

- 1- Mettre l'entraîneur 1
- 2- Positionner la vis adaptée à l'écrou ou au goujon à sertir (M5, M6, M8, M10, M12, M14)
- 3- Visser l'écrou de blocage 3 avec les 2 clés de serrage (bien serrer)
- 4- Visser le support de buse 4
- 5- Visser la buse 5 adaptée à l'écrou ou au goujon à sertir (M5, M6, M8, M10, M12, M14)
- 6- Positionner la molette d'entraînement 6 (poussez le bouton 7 pour l'insérer)

Pour enlever la molette, pousser le bouton 7 et tirer sur la molette

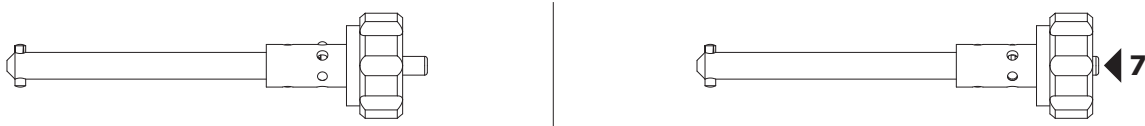

Couple vis et buse en fonction de l'insert à poser :

Écrou à sertir M14		Buse M14		Tige M14	
Écrou à sertir M12		Buse M12		Tige M12	
Écrou à sertir M10		Buse M10		Tige M10	

Ecrou à sertir M8		Buse M8	Tige M8 Vis M8
Ecrou à sertir M6		Buse M6	Tige M6 Vis M6
Ecrou à sertir M5		Buse M5	Tige M5 Vis M5
Goujon à sertir M8		Buse M8	Tige M8
Goujon à sertir M6		Buse M6	Tige M6
Goujon à sertir M5		Buse M5	Tige M5

Pose d'un écrou à sertir :

			Il y a deux méthodes pour poser les écrous à sertir :
1.	2. Visser l'écrou à sertir au moins jusqu'au bout de la tige.	3. Dévisser la buse contre l'insert et serrer le contre écrou.	4. Réglage pour pose des écrous à sertir.

1 / Pose à la pression

Suivant la taille de l'écrou à sertir, l'effort nécessaire à la pose varie.
Règles indicatives de la pose d'écrous à sertir (varie suivant les constructeurs).

Effort de pose recommandé par taille

Ø	Matière	Effort kN	Correspondance riveteuse 8T		Correspondance riveteuse 10T	
			Effort kN	Pression bar	Effort kN	Pression bar
M5	acier	8	16	1.6	16	1.1
M6	acier	12	24	2.4	24	1.6
M8	acier	18	36	3.6	36	2.5
M10	acier	21	42	4.2	42	3
M12	acier	23	46	4.6	46	3.2
M14	acier	50	-	-	100	6.5
M5	alu	3,8	7.6	0.8	7.6	0.5
M6	alu	5,5	11	1.1	11	0.75
M8	alu	10	20	2.0	20	1.5
M10	alu	12	24	2.4	24	1.6
M12	alu	15	30	3.0	30	2.0

Pour la pose à la pression, la course de l'adaptateur peut-être réglée à 25 mm (maxi).

Le réglage de l'effort se fait avec la riveteuse. (réglage avec le bouton et lecture de la pression).

1.1 / Options

Lecture du manomètre.

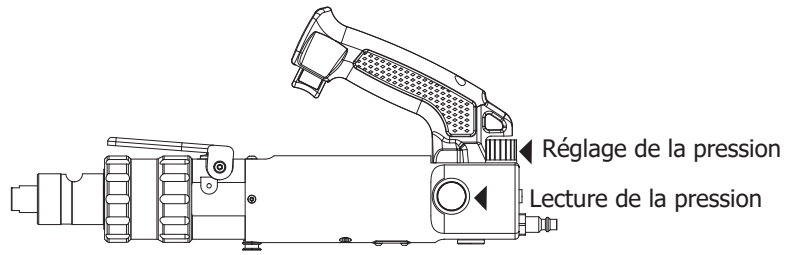

Lecture sur le capteur d'effort
(plus précis) solution à privilégier

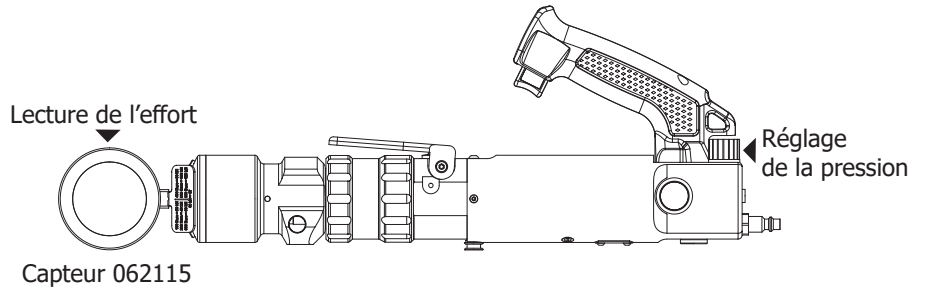

1.2 / Exemple

Écrou à sertir M10 acier à poser avec une riveteuse 10T.

Réglage de la course sur 25 mm.

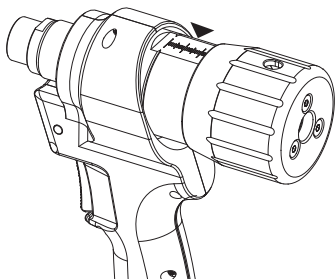

Réglage de la riveteuse avec capteur sur 210 bars qui correspond à 42 kN.

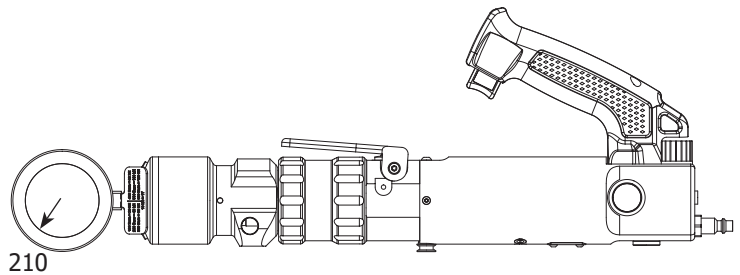

OU

Réglage de la riveteuse avec manomètre 3 bars
correspond à 42 kN.

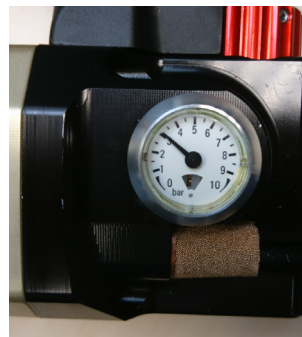

- Appuyer sur la commande de la riveteuse, et attendre qu'elle cale.
- Relâcher la gâchette et vérifier que l'insert est bien posé.
- Si l'écrou à sertir ne semble pas assez sertit, augmenter un peu l'effort de la riveteuse.
- Pour retirer la tige de traction de l'écrou à sertir, dévisser à l'aide de la molette arrière.

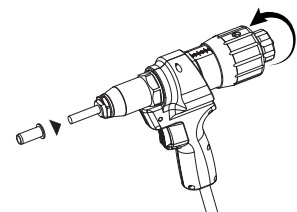

2/ Pose à la course

1. Mesurer la cote intérieure de l'écrou à sertir (A)
2. Mesurer la cote de l'épaisseur de la collerette (B)
3. Mesurer l'épaisseur de la tôle qui doit recevoir l'écrou à sertir (C)
4. Régler sur l'adaptateur le résultat obtenu (D)

avec la formule :

$$D = A - B - C$$

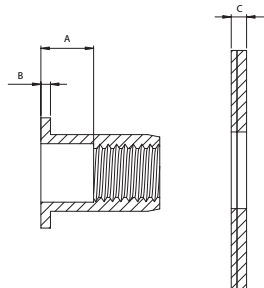
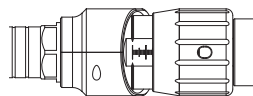
**2.1 / Exemple :**

Ecrrou à sertir M12 / Tôle épaisseur 2mm

1. Mesurer la cote intérieur de l'écrou à sertir (A) = 10.5mm
 2. Mesurer la cote de l'épaisseur de la collerette (B) = 2mm
 3. Mesurer l'épaisseur de la tôle qui doit recevoir l'insert (C) = 2mm
 4. Régler sur l'adaptateur le résultat obtenu
- $$D = 10.5 - 2 - 2 = 6.5 \text{ mm}$$

$$D = 10.5 - 2 - 2 = 6.5 \text{ mm}$$

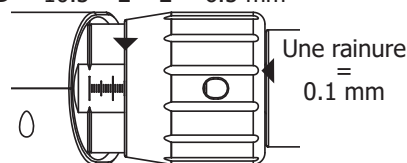

Pour un réglage le plus précis, s'aider de la graduation (en mm) et des rainures sur la molette.

Un tour de molette correspond à 1.5mm de course et il y a 15 rainures sur l'écrou.

5. appuyer sur la commande de la riveteuse, et attendre qu'elle cale.
6. Relâcher la gâchette et vérifier que l'écrou à sertir est bien posé.
7. Pour retirer la tige de traction de l'écrou à sertir, dévisser à l'aide de la molette arrière.

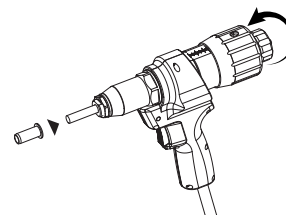

Le réglage incorrect de la course de l'outil, peut provoquer le mauvais serrage des écrous à sertir et la casse du tirant.

Le réglage de la course est essentiel pour la fixation de l'écrou à sertir.

Il faut considérer qu'une course excessive peut provoquer la casse du tirant, tandis qu'une course insuffisante ne garantit pas la stabilité de l'écrou à sertir.

Il est préférable d'y aller par étape en augmentant la course au fur et à mesure.

3 / Pose des gougeons à sertir :

Pour la pose des gougeons à sertir, une mesure de cote pour déformation n'est pas possible.

Il est préférable d'y aller par étape en augmentant la course au fur et à mesure.



KIT 3

RALLONGE POUR POSE DE RIVETS AVEUGLES POUR DIAMETRE DE TIGE JUSQU'À 5MM + EXTRACTION DE RIVET AUTO-POINÇONNEUR

Ordre de montage du kit 3 :

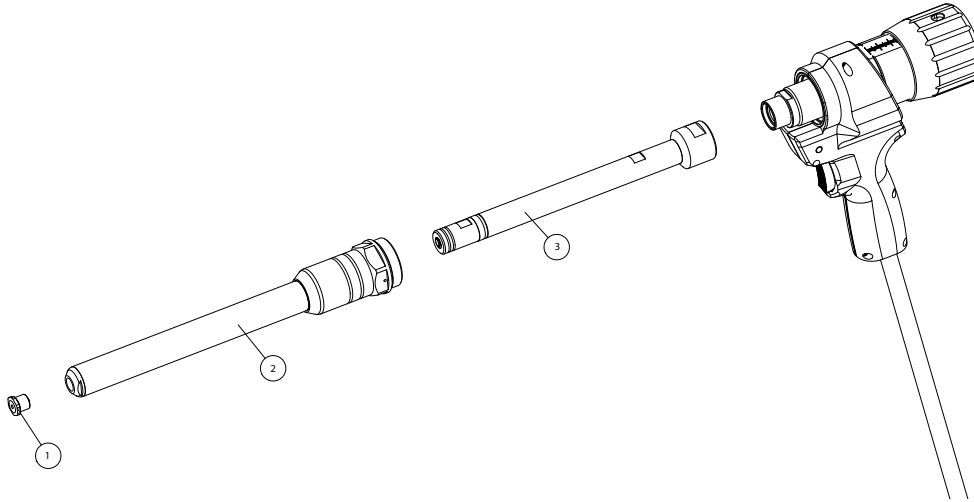

Pour utiliser le kit d'extension il n'est pas nécessaire d'utiliser le bol de récupération des tiges. Les tiges, une fois cassées sortent sur l'avant.

1. Visser le support de mors 3 avec les 2clés de serrage (bien serrer)
2. Visser le support de buse 2 avec les 2clés de serrage
3. Visser l'une de buse adaptée au rivet à poser (inclus dans kit de base)

- Ø3.2 ref : 065994
- Ø3.5 ref : 066007
- Ø4.0 ref : 066014
- Ø4.5 ref : 066021
- Ø5.0 ref : 066038

Pour faciliter la mise en place des buses :

- 1- Positionner un rivet dans la buse.
- 2- Insérer le rivet avec la buse dans le support monté.
- 3- Serrer la buse avec clé de serrage.

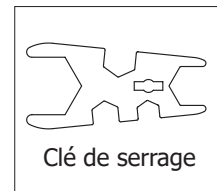

Pose d'un rivet aveugle :

Après avoir monté la buse adéquate, placer le rivet jusqu'en butée de la buse 

Placer le rivet à travers le trou des tôles à riveter et appuyer sur la gâchette de la riveteuse suivant le modèle ci-dessous :

GYPRESS 8T	GYPRESS 8T PP	GYPRESS 10T	GYPRESS 10T PP	GYPRESS 10T Connect

Une fois le rivet claqué, lâchez la gâchette . Pour les riveteuses 8T et 10 T appuyer sur la gâchette ci-dessous.

GYPRESS 8T	GYPRESS 10T

En penchant l'adaptateur sur l'avant, les tiges des rivets sortent par la buse.

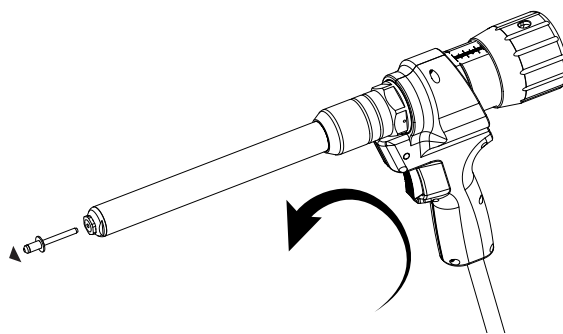

Remplacement des mors :

1- Liaison cône mors	M0042
2- Cone mors	M0043
3- Mors	058446
4- Écarteur	M0044
5- Ressort	55189
6- Rallonge	M0041
7- Poussoir	93058
8- Ressort	55223
9- Joint	55133

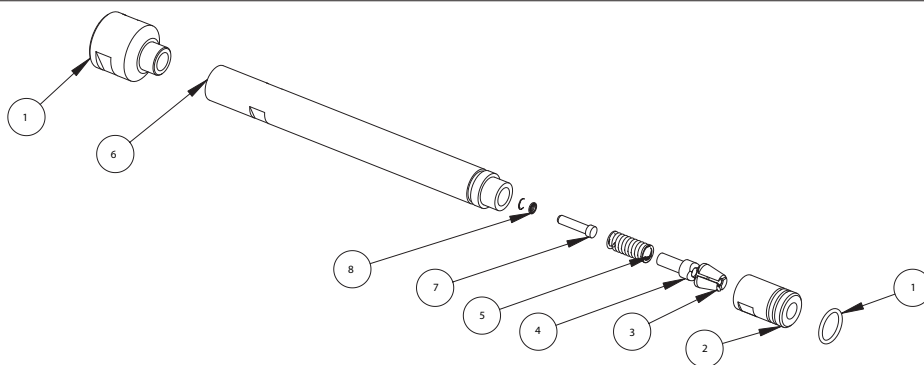

Dévisser 2 à l'aide des clés de serrage

Remplacer les mors 3 puis, les positionner dans 3 à 120°.

Placer successivement 4, 5, 7 et 8. Ensuite visser 6 à l'aide des clés (bien serrer).

Extraction de rivets auto poinçonneur : (voir chapitre précédent)

KIT 4

POSE DE RIVETS AVEUGLES Ø 9.8

Ordre de montage du kit 4 :

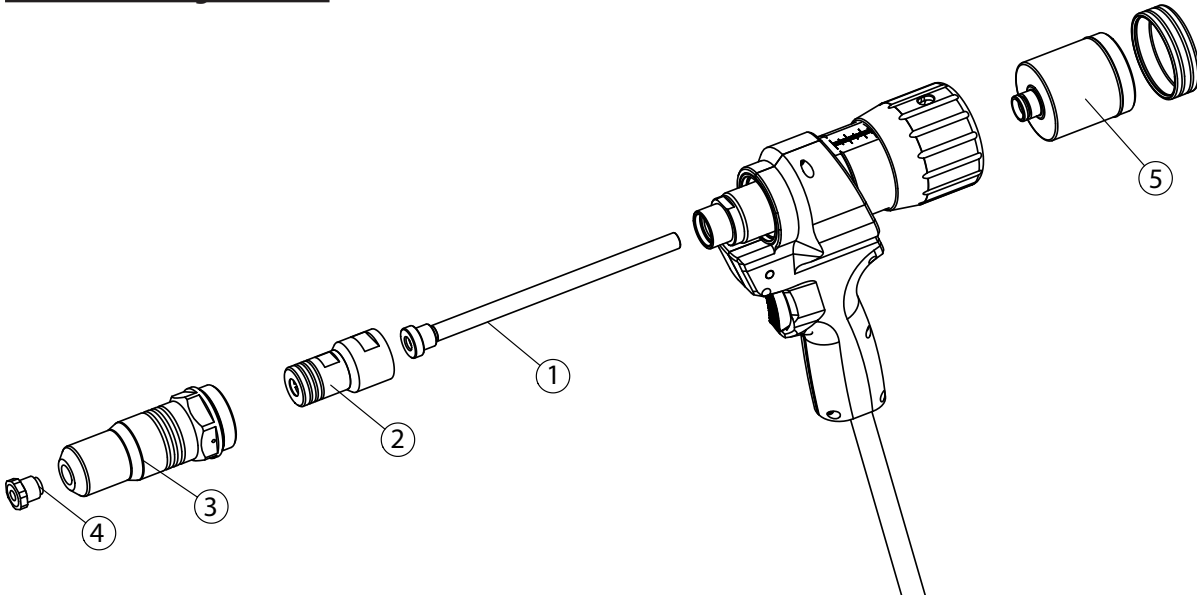

- 1- Mettre la tuyère 1.
- 2- Visser le support de mors 2 avec les 2 clés de serrage (bien serrer).
- 3- Visser le support de buse 3 avec les 2 clés de serrage.
- 4- Visser la buse Ø6 ref : 066052.
- 5- Enfiler le bol de récupération 5.



Pour faciliter la mise en place des buses :

- 1- Positionner un rivet dans la buse.
- 2- Insérer le rivet avec la buse dans le support monté.
- 3- Serrer la buse avec clé de serrage.



Pose d'un rivet aveugle :

Après avoir monté la buse adéquate, placer le rivet jusqu'en butée de la buse 

Placer le rivet à travers le trou des tôles à riveter et appuyer sur la gâchette de la riveteuse suivant le modèle ci-dessous :

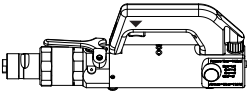
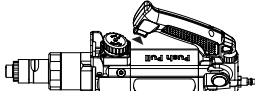
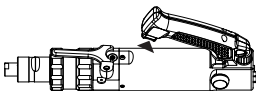
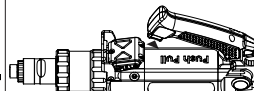
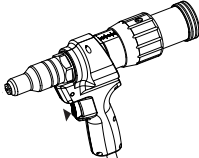
GYPRESS 8T	GYPRESS 8T PP	GYPRESS 10T	GYPRESS 10T PP	GYPRESS 10T Connect
				

Une fois le rivet claqué, lâchez la gâchette . Pour les riveteuses 8T et 10 T appuyer sur la gâchette ci-dessous.

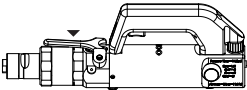
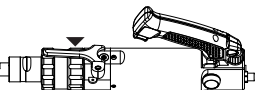
GYPRESS 8T	GYPRESS 10T
	

En penchant l'adaptateur en arrière, les tiges des rivets tombent dans le bol de récupération.
En penchant vers l'avant, les tiges sortent par la buse.

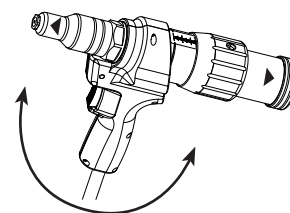

Récupération des tiges :

Pour récupérer les tiges, tirez sur le couvercle du bol.
Une fois les tiges récupérées remettre le couvercle jusqu'au clic.

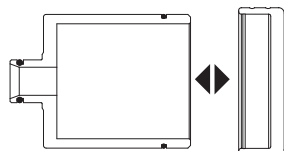

- | | |
|------------------|-------|
| 1- Bol | M0077 |
| 2- Couvercle | M0078 |
| 3- Joint torique | 55262 |
| 4- Joint torique | 55121 |

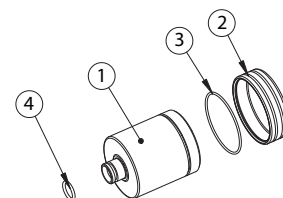

Remplacement des mors :

Dévisser a l'aide des clés de serrage.
Remplacer les mors 2 puis, les positionner dans 3 à 120°.
Placer 4 puis 5 et ensuite visser 1 a l'aide des clés (bien serrer).



Clé de serrage

- | | |
|----------------------|-------|
| 1- Liaison cône mors | M0042 |
| 2- Mors | 51522 |
| 3- Cône mors | M0043 |
| 4- Écarteur | M0044 |
| 5- Ressort | 55189 |

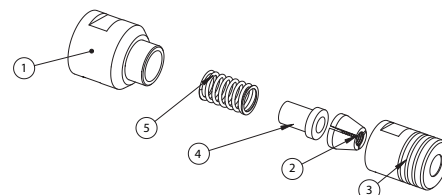

DESCRIPTION

The blind rivet adapter is compatible with the GYSPRESS 8T/10T and GYSPRESS 8T/10T PUSH PULL riveters. Its tensile force is 50 kN. It allows the setting of blind rivets with diameters from 4.0 to 7.8 mm for aluminium and 4.0 to 6.4 mm for steel.

SAFETY INSTRUCTIONS



- The 50KN adapter must not be used for anything other than setting blind rivets and blind rivet nuts and bolts.
- Mandatory wearing: safety glasses, anti-noise protection, safety gloves. Never point the nose of the tool towards yourself or anyone else.
- Never exceed the maximum allowable pressure of 7 bar.
- Blind rivets must be used according to the specifications..
- Fit the end cap according to the size of the rivet. Never force the rivet tail into the nozzle. Never use a nozzle wider than the rivet tail.
- Check that the clamping of the part to be riveted is correct.
- Hold the riveter firmly until the rivet tail cut is completed and ejected. Otherwise, release the trigger and then resume pulling by pressing the trigger again,
- Always unplug the machine after each use and after changing the riveting head.
- Keep this user manual in a safe place. In case of loss, please contact us.

ENVIRONMENT

This equipment must only be used for riveting operations in accordance with the limits indicated on the descriptive panel and/or in the user manual. Safety instructions must be followed. In case of improper or unsafe use, the manufacturer cannot be held liable.

This equipment must be used and stored in a room free from dust, acid, flammable gas or any other corrosive agent. Operate the machine in an open, or well-ventilated area.

Operating temperature:

Use between -10 and +40°C (+14 and +104°F).

Storage between -20 and +55°C (-4 and 131°F).

Air humidity:

Lower or equal to 50% at 40°C (104°F).

Lower or equal to 90% at 20°C (68°F).

Altitude:

Up to 1000 meters above sea level (3280 feet).

IN CASE OF A BREAKDOWN

The riveting operation is not performed:

- Check that the stroke adjusting nut is set to the correct value.
- Check that the riveter being used is working properly.
- Check for oil or compressed air leaks.

MAINTENANCE INSTRUCTIONS

- Keep the tool in a good state of cleanliness. Periodically check that the compressed air connections are in good condition and that the 50 kN adapter (the natural play between the rivet shank and the bit) is working properly.
- In case of oil leakage, remove from the riveting machine and turn the tool over.
- Replacing the jaws (see p.20)

SUMMARY

Riveting Machines	Power
GYSPRESS 8T	40 kN
GYSPRESS 8T PP	40 kN
GYSPRESS 10T	50 kN
GYSPRESS 10T PP	50 kN
GYSPRESS 10T Connect	50 kN

INSTALLATION ON GYSPRESS

GYSPRESS 8T :

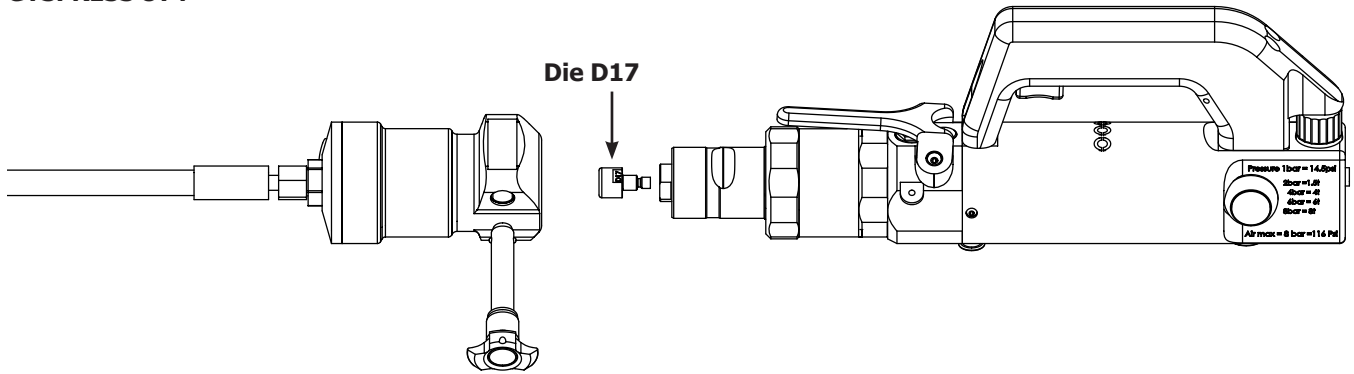

GYSPRESS 8T PP :

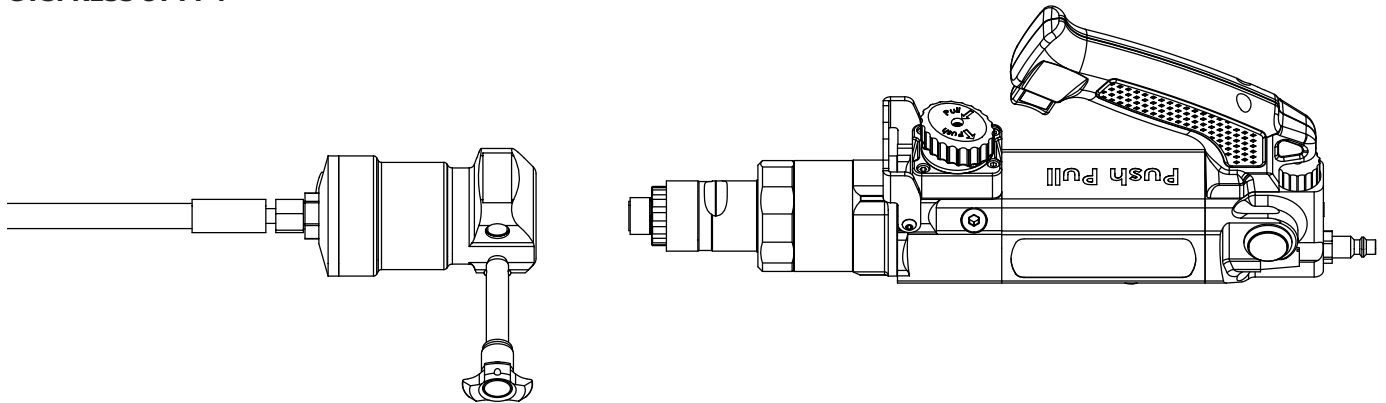

GYSPRESS 10T :

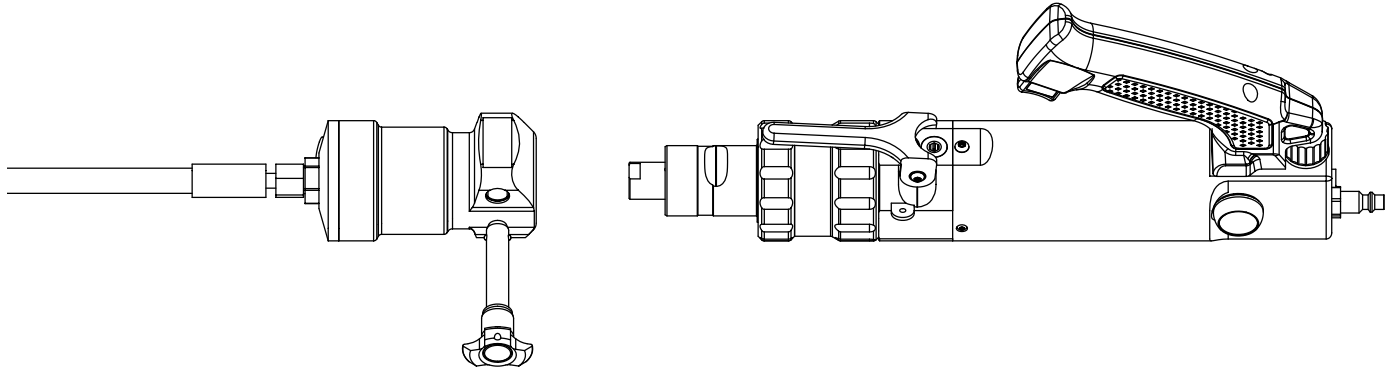

GYSPRESS 10T Connect :

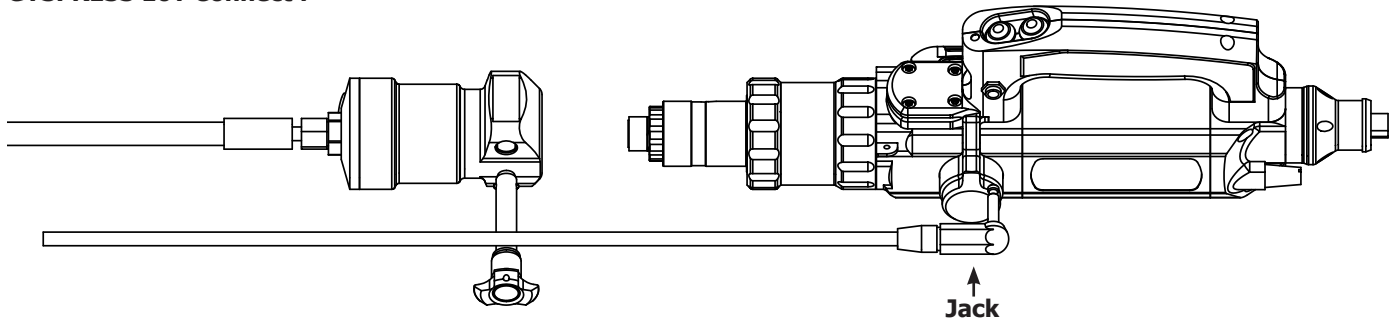

ADAPTER FORCE SETTINGS

The pulling strength is based on the effort supplied by the riveter:

Correspondence table with the pulling strength provided by the riveting machine and the air pressure at the riveter inlet.

Air pressure	2 bar / 29 Psi		3 bar / 44 Psi		4 bar / 58 Psi		5 bar / 72 Psi		6 bar / 87 Psi		6,5 bar / 94 Psi		7 bar / 101 Psi		8 bar / 116 Psi	
Effort	Riveting Machine	Adapter	Riveting Machine	Adapter	Riveting Machine	Adapter	Riveting Machine	Adapter	Riveting Machine	Adapter	Riveting Machine	Adapter	Riveting Machine	Adapter	Riveting Machine	Adapter
GYPRESS 8T	20 kN	10 kN	30 kN	15 kN	40 kN	20 kN	50 kN	25 kN	60 kN	30 kN	65 kN	32,5 kN	70 kN	35 kN	80 kN	40 kN
GYPRESS 8T PP	20 kN	10 kN	30 kN	15 kN	40 kN	20 kN	50 kN	25 kN	60 kN	30 kN	65 kN	32,5 kN	70 kN	35 kN	80 kN	40 kN
GYPRESS 10T	29 kN	19,5 kN	44 kN	22 kN	58 kN	29 kN	72 kN	36 kN	87 kN	43,5 kN	100 kN	50 kN	100 kN	50 kN	100 kN	50 kN
GYPRESS 10T PP	29 kN	19,5 kN	44 kN	22 kN	58 kN	29 kN	72 kN	36 kN	87 kN	43,5 kN	100 kN	50 kN	100 kN	50 kN	100 kN	50 kN
GYPRESS 10T Connect	29 kN	19,5 kN	44 kN	22 kN	58 kN	29 kN	72 kN	36 kN	87 kN	43,5 kN	100 kN	50 kN	100 kN	50 kN	100 kN	50 kN

STROKE SETTINGS

The adapter stroke is adjustable from 0 to 25 mm.
This is done by using the A knob.
Screw it in tightly to get 0 stroke.
Unscrew all the way down to have 25 mm of travel.

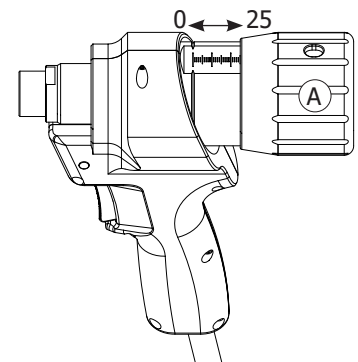

DIFFERENT KITS ON ADAPTER

Kit 1 :

Blind rivet installation for shank diameter up to 5 mm + self-pierce rivet extraction.

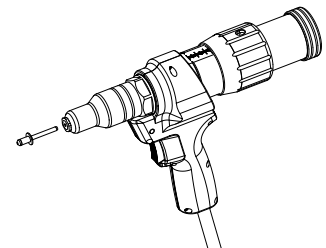

Kit 2 :

Installation of blind rivet nuts and bolts M5 to M14.

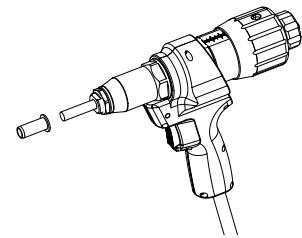

Kit 3 :

Extension for Blind rivet installation for shank diameter up to 5 mm + self-pierce rivet extraction.

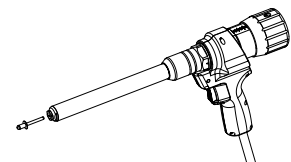

Kit 4 :

Installation of blind rivets \varnothing 9.8 mm.

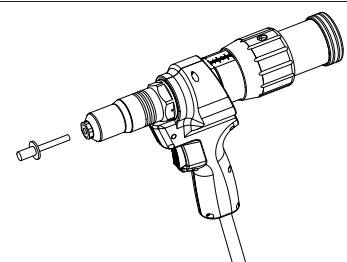

KIT 1

BLIND RIVET INSTALLATION FOR SHANK DIAMETER UP TO 5 MM + SELF-PIERCE RIVET EXTRACTION.

Assembly order of kit 1:

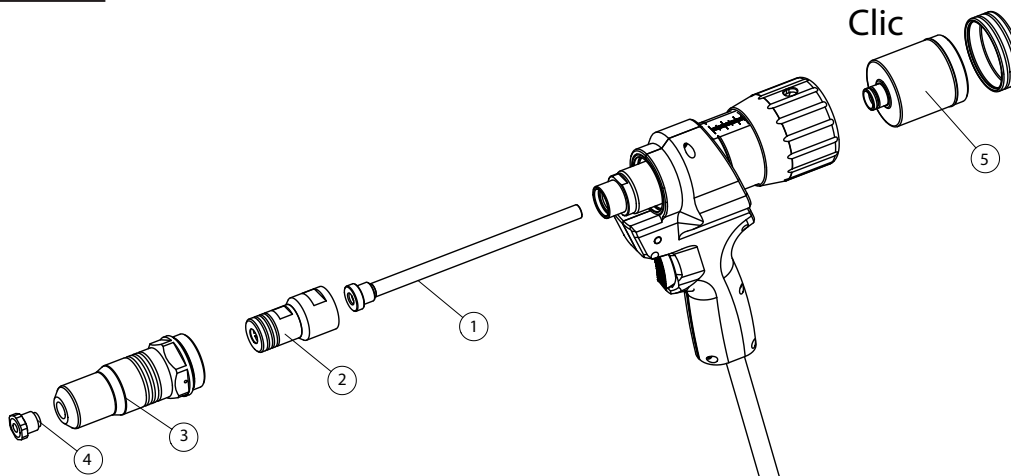

- 1- Insert nozzle 1
- 2- Screw the jaw support 2 with the 2 spanners (tighten well)
- 3- Screw the nozzle holder 3 with the 2 spanners
- 4- Screw one of the nozzles adapted to the rivet to be set:

- Ø3.2 ref : 065994
- Ø3.5 ref : 066007
- Ø4.0 ref : 066014
- Ø4.5 ref : 066021
- Ø5.0 ref : 066038

To facilitate the installation of the nozzles:

- 1- Position a rivet into the nozzle.
- 2- Insert the rivet with the nozzle into the assembled support.
- 3- Tighten the nozzle with a spanner.

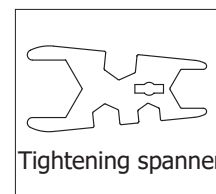

- 5- Thread the recovery bowl

Blind rivet setting:

After fitting the appropriate nozzle, place the rivet as far as the nozzle end stop

Place the rivet through the hole in the sheets to be riveted and press the riveter trigger according to the model below:

GYPRESS 8T	GYPRESS 8T PP	GYPRESS 10T	GYPRESS 10T PP	GYPRESS 10T Connect

Once the rivet has been set, release the trigger. For 8T and 10T riveters press the trigger below.

GYPRESS 8T	GYPRESS 10T

By tilting the adapter backwards, the rivet pins fall into the collecting bowl.
By leaning forward, the pins come out through the nozzle.

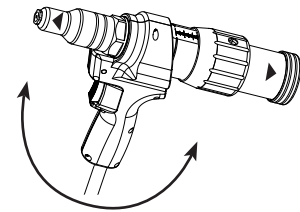

Pin collection:

To collect the pins, pull the lid off the bowl.
Once the pins have been collected, put the lid back on until it clicks.

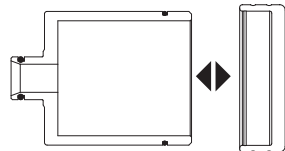

- 1- Bowl M0077
- 2- Lid M0078
- 3- O-ring 55262
- 4- O-ring 551211

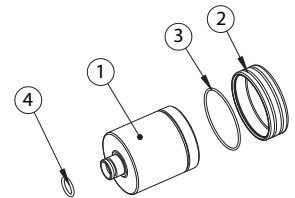

Clamping jaws change:

Unscrew the nozzle with a spanner.
Replace the jaws 2 then, position them in 3 to 120°.
Place 4 then 5 and then screw 1 with the keys (tighten well).

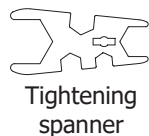

- 1- Connection cone jaws M0042
- 2- Jaws (ref. 058446) 51522
- 3- M0043 jaw cone
- 4- Spreader M0044
- 5- Spring 55189

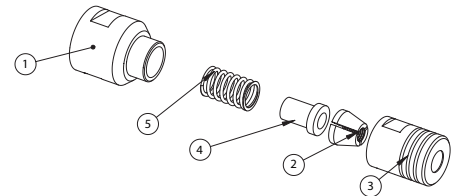

Self-piercing rivet extraction:

The kit can be fitted with a special nozzle for extracting self-piercing rivets by welding a pin to the rivet (ref. 066151).

Nozzle assembling:

Install the extraction nozzle 066151 on the nozzle holder.

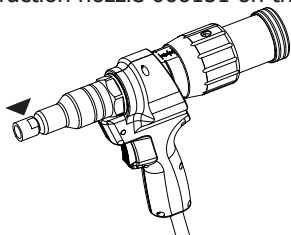

Set the stroke adjusting nut to 15mm

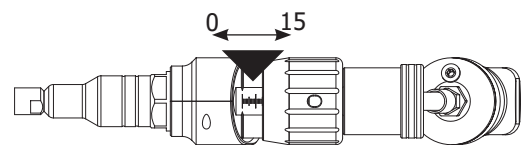

Extraction stages:

1- Welding of the extraction pin:
Material: ARC PULL 350 062191 + ARC PULL RIVET BOX 064584

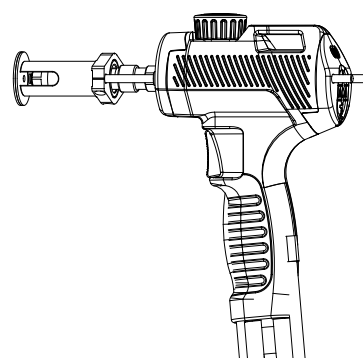
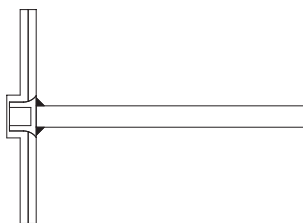

2- Insert the rivet extraction pin all the way into the gun, with the nozzle in contact with the sheet metal:

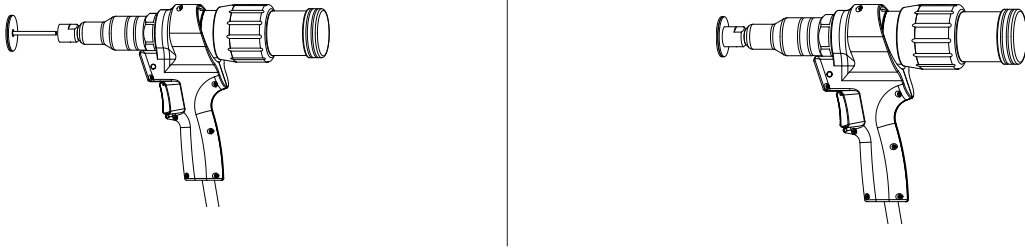

3- Operate the adapter according to the models below:

GYSPRESS 8T	GYSPRESS 8T PP	GYSPRESS 10T	GYSPRESS 10T PP	GYSPRESS 10T Connect

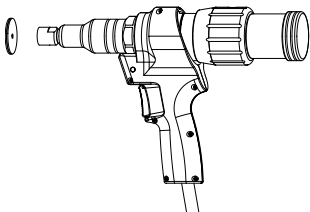

Once the rivet has been pulled out of the sheet, release the trigger. For 8T and 10T riveters press the trigger below.

GYSPRESS 8T	GYSPRESS 10T

Rivet and pin pop out at the front:

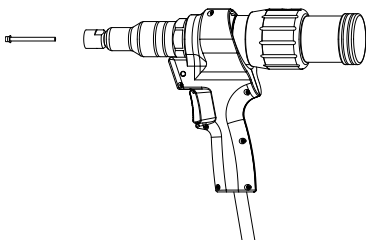

KIT 2

INSTALLATION OF BLIND RIVET NUTS AND BOLTS M5 TO M14.

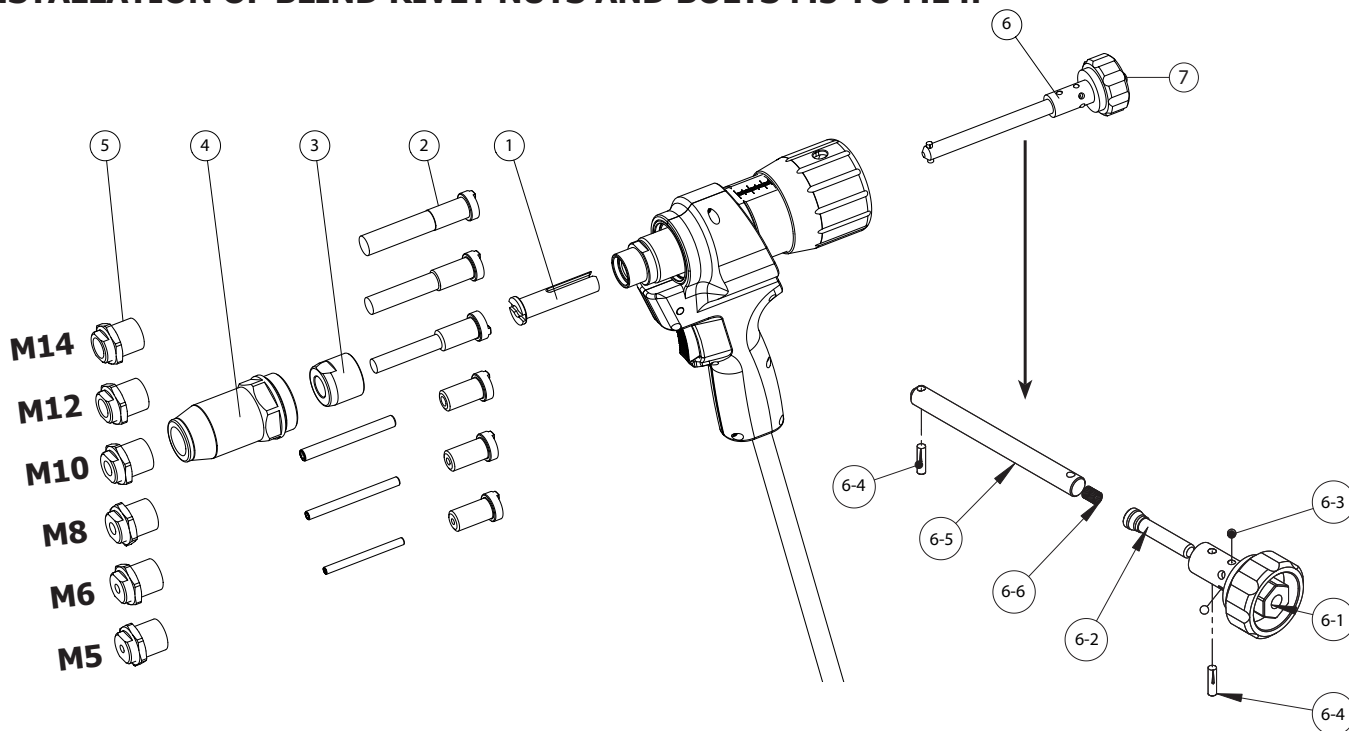

Assembly order of kit 2:





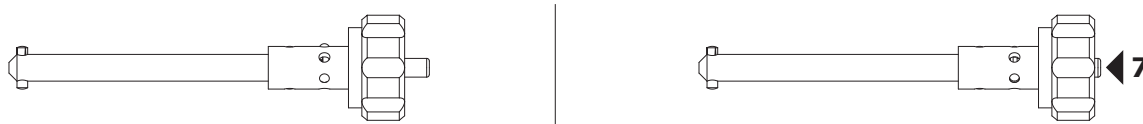





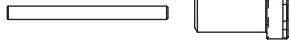

- 1- Put on the driver 1
- 2- Position the screw adapted to the blind rivet nut or bolt (M5, M6, M8, M10, M12, M14).
- 3- Screw on the locking nut 3 with the 2 spanners (tighten well)
- 4- Screw the nozzle holder 4
- 5- Screw the nozzle 5 adapted to the blind rivet nut or bolt (M5, M6, M8, M10, M12, M14)
- 6- Position drive wheel 6 (push button 7 to insert it)

To remove the knob, push button 7 and pull the knob.

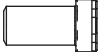

Pair of screws and nozzle depending on the insert to be installed:

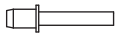
Blind rivet nuts M14			Nozzle M14		Rod M14
Blind rivet nuts M12			Nozzle M12		Rod M12
Blind rivet nuts M10			Nozzle M10		Rod M10
Blind rivet nuts M8			Nozzle M8		Rod M8 Screw M8

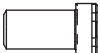
Blind rivet nuts M6 	 Nozzle M6	 Rod M6 Screw M6
Blind rivet nuts M5 	 Nozzle M5	 Rod M5 Screw M5
Blind rivet bolts M8 	 Nozzle M8	 Rod M8
Blind rivet bolts M6 	 Nozzle M6	 Rod M6
Blind rivet bolts M5 	 Nozzle M5	 Rod M5

Blind rivet nut installation:

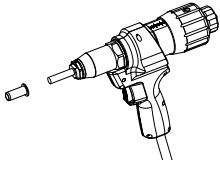
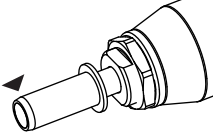
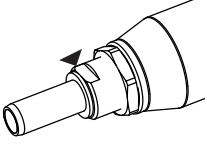
			There are two ways to install blind rivet nuts:
1.	2. Screw on the blind rivet nut at least to the end of the pin.	3. Unscrew the nozzle against the insert and tighten the lock nut.	4. Adjustment for the installation of blind rivet nuts.

1 / Pressure installation

Depending on the size of the blind rivet nut, the effort required for installation varies.
Indicative rules for the installation of blind rivet nuts (varies according to the manufacturer).

Recommended installation effort per size

Ø	Material	Effort kN	Riveting machine 8T correlation		Riveting machine 10T correlation	
			Effort kN	Bar pressure	Effort kN	Bar pressure
M5	steel	8	16	1.6	16	1.1
M6	steel	12	24	2.4	24	1.6
M8	steel	18	36	3.6	36	2.5
M10	steel	21	42	4.2	42	3
M12	steel	23	46	4.6	46	3.2
M14	steel	50	-	-	100	6.5
M5	alu	3,8	7.6	0.8	7.6	0.5
M6	alu	5,5	11	1.1	11	0.75
M8	alu	10	20	2.0	20	1.5
M10	alu	12	24	2.4	24	1.6
M12	alu	15	30	3.0	30	2.0

For pressure installation, the adapter stroke can be set to 25 mm (max.).
The force is adjusted with the riveting machine. (adjustment with the button and pressure reading).

1.1 / Options

Pressure gauge reading.

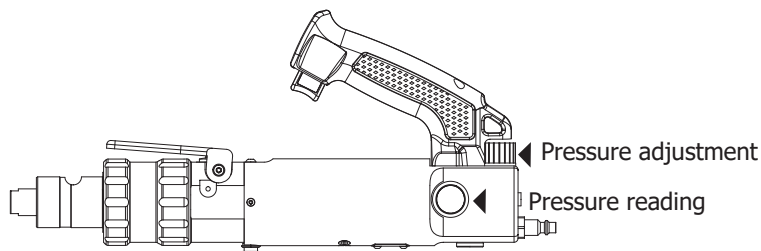

Reading on the effort sensor
(more accurate) solution to be favoured

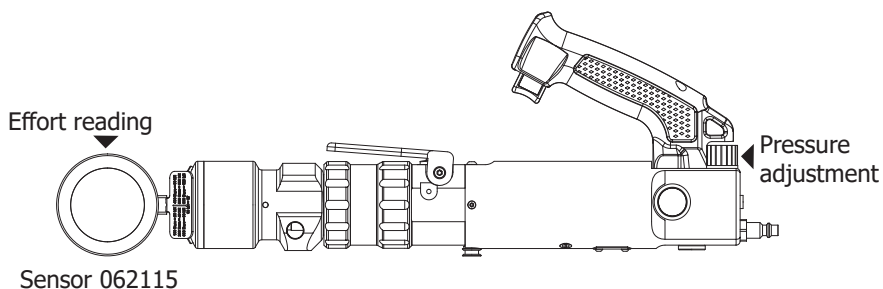

1.2 / Example

Blind rivet nut M10 steel to be set with a 10T riveting machine.

Stroke adjustment on 25 mm.

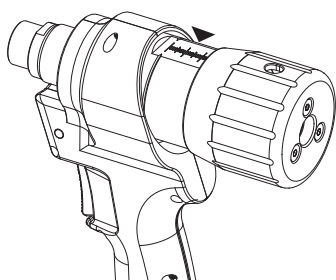

Adjustment of the riveting machine with sensor to 210 bar which corresponds to 42 kN.

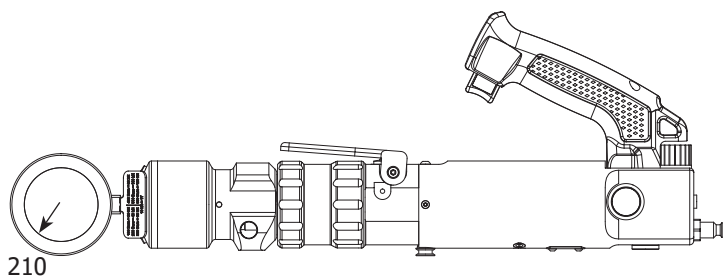

OU

Adjustment of the riveting machine with manometer to 3 bar which corresponds to 42 kN.

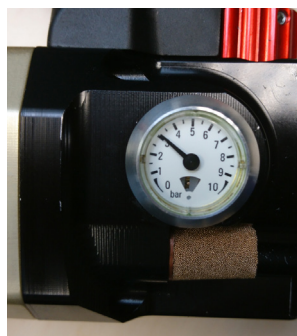

- Press the riveter control and wait for the riveter to wedge.
- Release the trigger and check that the insert is correctly in place.
- If the blind rivet nut does not seem to be crimped enough, increase the riveter's effort a little more.
- To remove the pull pin from the blind rivet nut, unscrew with the rear knob.

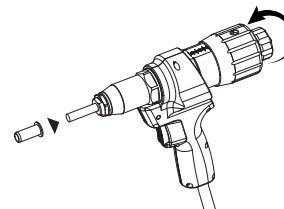

2/ Installation with the stroke

1. Measure the inside dimension of the blind rivet nut (A)
2. Measure the dimension of the flange thickness (B)
3. Measure the thickness of the sheet metal that is to receive the blind rivet nut (C).
4. Adjust the result (D) with the formula on the adapter:
 $D = A - B - C$

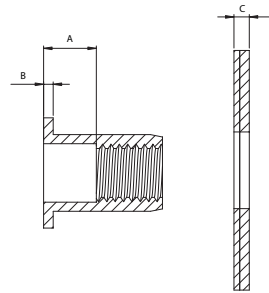
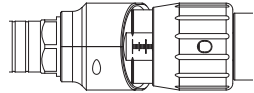

2.1 / Example :

Blind rivet nut M12 / Sheet metal thickness 2mm

1. Measure the inside dimension of the blind rivet nut (A) = 10.5mm
2. Measure the dimension of the flange thickness (B) = 2mm
3. Measure the thickness of the sheet metal that is to receive the insert (C) = 2mm
4. Adjust the result on the adapter
 $D = 10.5 - 2 - 2 = 6.5 \text{ mm}$

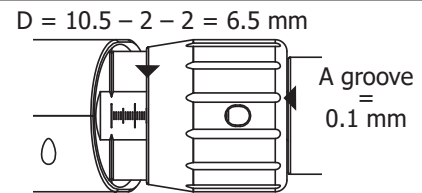

For a more precise adjustment, use the scale (in mm) and the grooves on the wrench adjuster.

One turn of the wrench adjuster corresponds to 1.5mm of travel and there are 15 grooves on the nut.

5. Press the riveter control and wait for the riveter to wedge.
6. Release the trigger and check that the insert is correctly in place.
7. To remove the pull pin from the blind rivet nut, unscrew with the rear wrench adjuster.

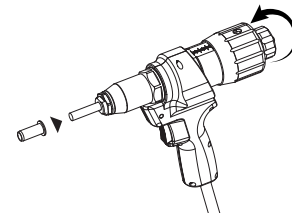

Incorrect adjustment of the tool stroke can lead to incorrect tightening of the blind rivet nuts and breakage of the tie rod. The adjustment of the stroke is essential for the fixing of the blind rivet nut.

It must be considered that an excessive stroke can cause the breakage of the tie rod, while an insufficient stroke does not guarantee the stability of the blind rivet nut.

It is advisable to go in stages, increasing the stroke as you go along.

3 / Blind rivet bolts installation:

A dimensional measurement for deformation is not possible when installing blind rivet bolts.

It is advisable to go in stages, increasing the stroke as you go along.

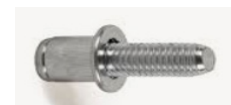

KIT 3

EXTENSION FOR BLIND RIVET INSTALLATION FOR SHANK DIAMETER UP TO 5 MM + SELF-PIERCE RIVET EXTRACTION.

Assembly order of kit 3:

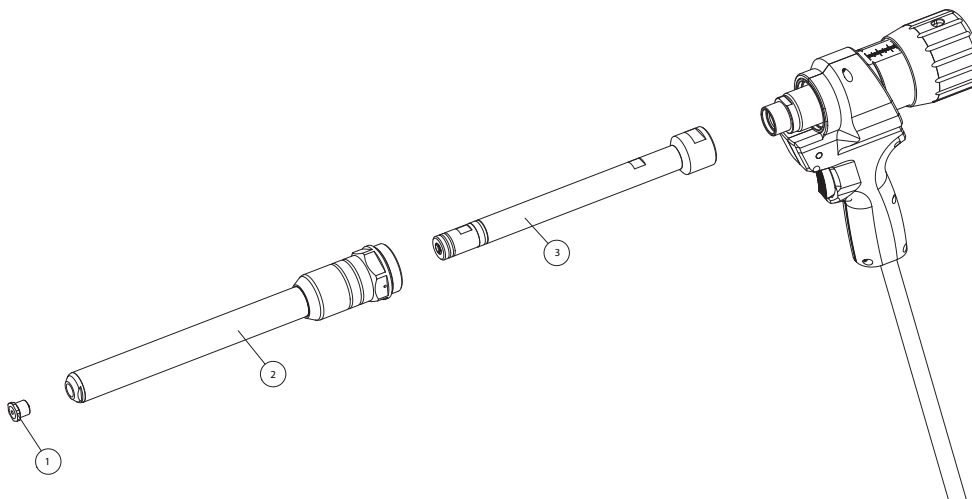

To use the extension kit it is not necessary to use the pin collecting bowl.
The pins, once broken, come out at the front.

1. Screw on the jaw support 3 with the 2 spanners (tighten well)
2. Screw on nozzle holder 2 with the 2 spanners.
3. Screw on one of the nozzles adapted to the rivet to be set (included in the standard kit)

Ø3.2 ref : 065994
Ø3.5 ref : 066007
Ø4.0 ref : 066014
Ø4.5 ref : 066021
Ø5.0 ref : 066038

To facilitate the installation of the nozzles:

- 1- Position a rivet into the nozzle.
- 2- Insert the rivet with the nozzle into the assembled support.
- 3- Tighten the nozzle with a spanner.

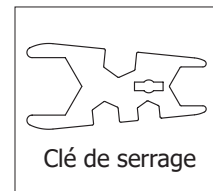
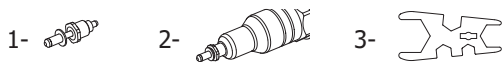

Blind rivet setting:

After fitting the appropriate nozzle, place the rivet as far as the nozzle end stop. 

Place the rivet through the hole in the sheets to be riveted and press the riveter trigger according to the model below:

GYPRESS 8T	GYPRESS 8T PP	GYPRESS 10T	GYPRESS 10T PP	GYPRESS 10T Connect

Once the rivet has been set, release the trigger. For 8T and 10T riveters press the trigger below.

GYPRESS 8T	GYPRESS 10T

By leaning forward, the rivet's pins come out through the nozzle.

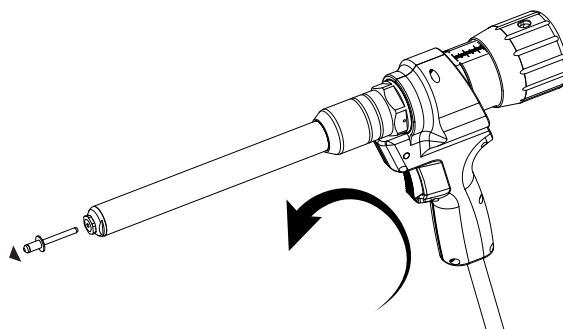

Clamping jaws change:

- 1- Connection cone jaws M0042
- 2- Cone jaws M0043
- 3- Jaws 058446
- 4- Spreader M0044
- 5- Spring 55189
- 6- Extension M0041
- 7- Pusher 93058
- 8- Spring 55223
- 9- Joint 55133

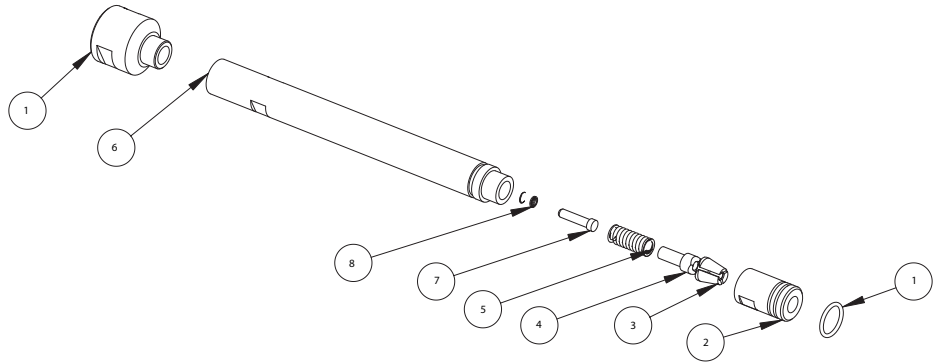

Unscrew 2 with the spanners
Replace the jaws 3 and then position them in 3 at 120°.
Place 4, 5, 7 and 8 in succession. Then screw in 6 with the spanners (tighten well).

Extraction of self-piercing rivets: (see previous chapter)

KIT 4

ASSEMBLY ORDER OF KIT 4:

Assembly order of kit 4:

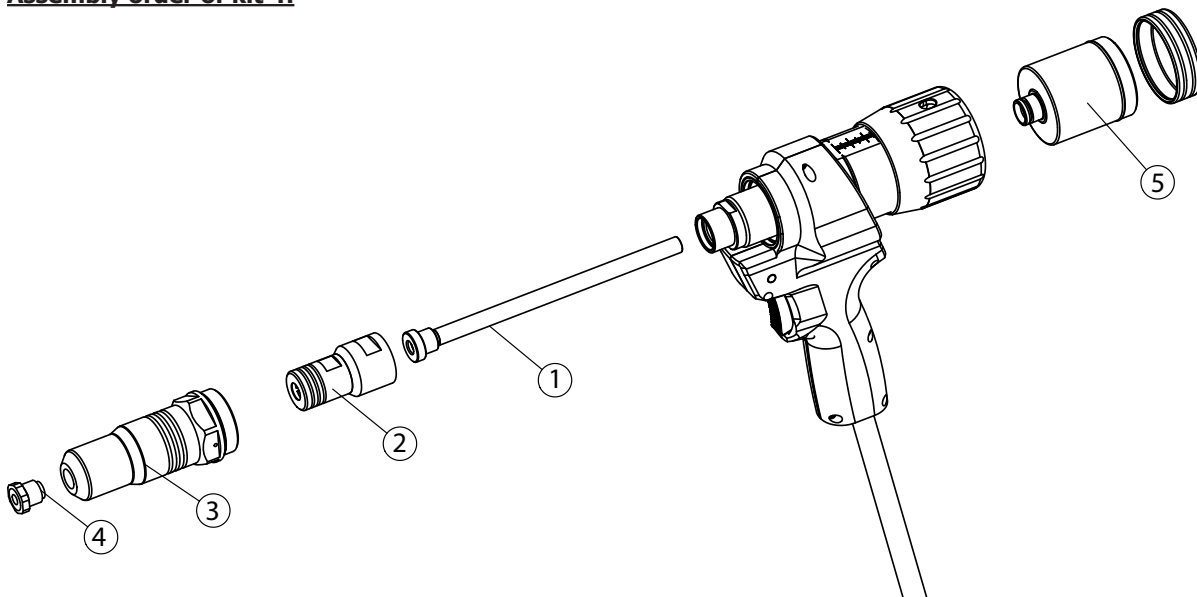

- 1- Set the Tailpipe 1.
- 2- Screw on the jaw support 2 with the 2 spanners (tighten well)
- 3- Screw on nozzle holder 3 with the 2 spanners.
- 4- Screw the nozzle Ø6 ref: 066052.
- 5- Thread the recovery bowl 5.

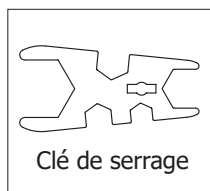

To facilitate the installation of the nozzles:

- 1- Position a rivet into the nozzle.
- 2- Insert the rivet with the nozzle into the assembled support.
- 3- Tighten the nozzle with a spanner.



Blind rivet setting:

After fitting the appropriate nozzle, place the rivet as far as the nozzle end stop



Place the rivet through the hole in the sheets to be riveted and press the riveter trigger according to the model below:

GYPESPRESS 8T	GYPESPRESS 8T PP	GYPESPRESS 10T	GYPESPRESS 10T PP	GYPESPRESS 10T Connect

Once the rivet has been set, release the trigger. For 8T and 10T riveters press the trigger below.

GYPESPRESS 8T	GYPESPRESS 10T

By tilting the adapter backwards, the rivet pins fall into the collecting bowl.
By leaning forward, the pins come out through the nozzle.

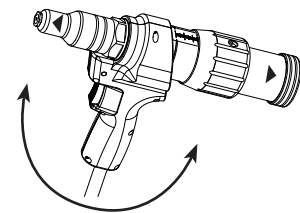

Pin collection:

To collect the pins, pull the lid off the bowl.
Once the pins have been collected, put the lid back on until it clicks.

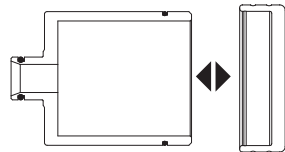

- 1- Bowl M0077
- 2- Lid M0078
- 3- O-ring 55262
- 4- O-ring 551211

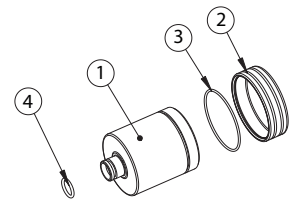

Clamping jaws change:

Unscrew the nozzle with a spanner.
Replace the jaws 2 then, position them in 3 to 120°.
Place 4 then 5 and then screw 1 with the keys (tighten well).

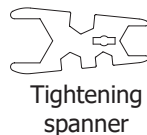

- 1- Connection cone jaws M0042
- 2- Jaws 51522
- 3- M0043 jaw cone
- 4- Spreader M0044
- 5- Spring 55189

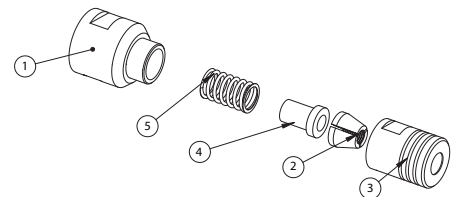

DESCRIPCIÓN

El adaptador para remaches ciegos es compatible con las remachadoras GYSPRESS 8T/10T y GYSPRESS 8T PUSH PULL. Su fuerza de remachado es de 24 kN. Permite colocar remaches ciegos de diámetro 4.0 a 7.8 mm para aluminio y de 4.0 a 6.4 mm para acero, así como tuercas y espárragos remachables.

CONSIGNAS DE SEGURIDAD



- El adaptador de 50KN no debe usarse para nada más que para colocar remaches ciegos, tuercas y espárragos remachables.
- Uso obligatorio: gafas de seguridad, protección contra el ruido, guantes de seguridad. Nunca apunte la punta de la herramienta hacia usted o hacia nadie más.
- Nunca supere la presión máxima permitida de 7 bares.
- Utilice obligatoriamente remaches ciegos según las especificaciones.
- Instale la contera de acuerdo con el tamaño del remache. Nunca fuerce para colocar la varilla del remache en la contera. Nunca utilice una contera más ancha que la varilla del remache.
- Compruebe que la sujeción de la pieza a remachar sea correcta..
- Sostenga la remachadora firmemente hasta que el corte de la varilla del remache esté completo y que la varilla sea expulsada. En caso contrario, suelte el gatillo y vuelva a apretar el gatillo de nuevo,
- Desenchufe siempre la máquina después de cada uso y al cambiar la contera de remachado..
- Guarde este manual en un lugar seguro. En caso de pérdida, por favor contáctenos.

ENTORNO

Este material se debe utilizar solamente para realizar operaciones de remachado dentro de los límites indicados en el aparato y el manual. Se deben respetar las instrucciones relativas a la seguridad. En caso de uso inadecuado o peligroso, el fabricante no podrá considerarse responsable.

La instalación se debe hacer en un local sin polvo, ni ácido, ni gas inflamable u otras sustancias corrosivas incluso donde se almacene el producto. Hay que asegurarse de que haya una buena circulación de aire cuando se esté utilizando.

Zona de temperatura :

Uso entre -10 y +40°C (+14 y +104°F).

Almacenado entre -20 y +55°C (-4 y 131°F).

Humedad del aire :

Inferior o igual a 50% a 40°C (104°F).

Inferior o igual a 90% a 20°C (68°F).

Altitud:

Hasta 1000m por encima del nivel del mar (3280 pies).

EN CASO DE AVERÍA

La operación de remachado no se realiza:

- Compruebe que la tuerca de ajuste de la carrera está ajustada al valor correcto.
- Compruebe que la remachadora que se está usando funciona correctamente..
- Compruebe si hay fugas de aceite o aire comprimido.

INSTRUCCIONES DE MANTENIMIENTO

- Mantén la herramienta en un estado limpio. Compruebe periódicamente el buen estado de las conexiones de aire comprimido, el correcto funcionamiento del adaptador de 50 kN (el juego natural entre el vástago del remache y la broca).
- En caso de fuga de aceite, retire del remachador y déle la vuelta a la herramienta.
- Reemplazar las mandíbulas (ver p.33)

RESUMEN

Remachadoras	Potencia
GYSPRESS 8T	40 kN
GYSPRESS 8T PP	40 kN
GYSPRESS 10T	50 kN
GYSPRESS 10T PP	50 kN
GYSPRESS 10T Connect	50 kN

INSTALACIÓN SOBRE GYSPRESS

GYSPRESS 8T :

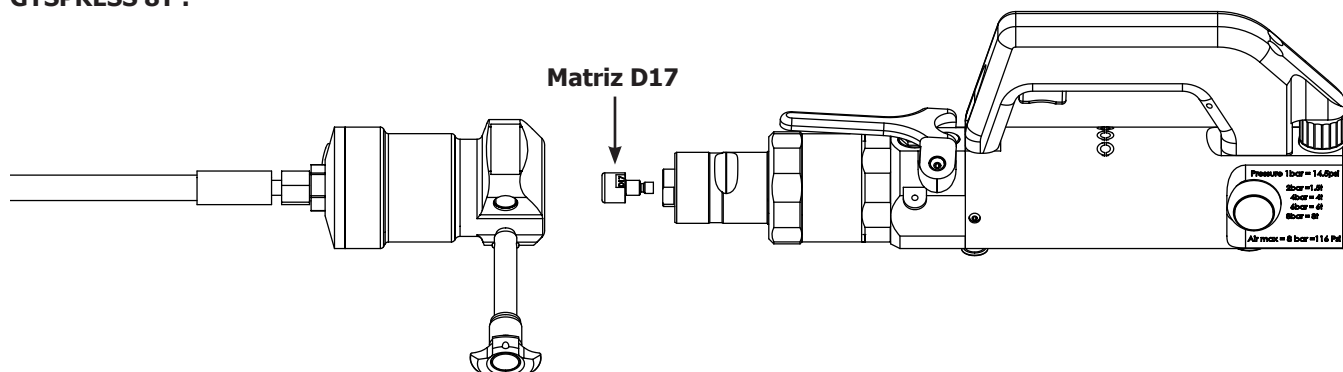

GYSPRESS 8T PP :

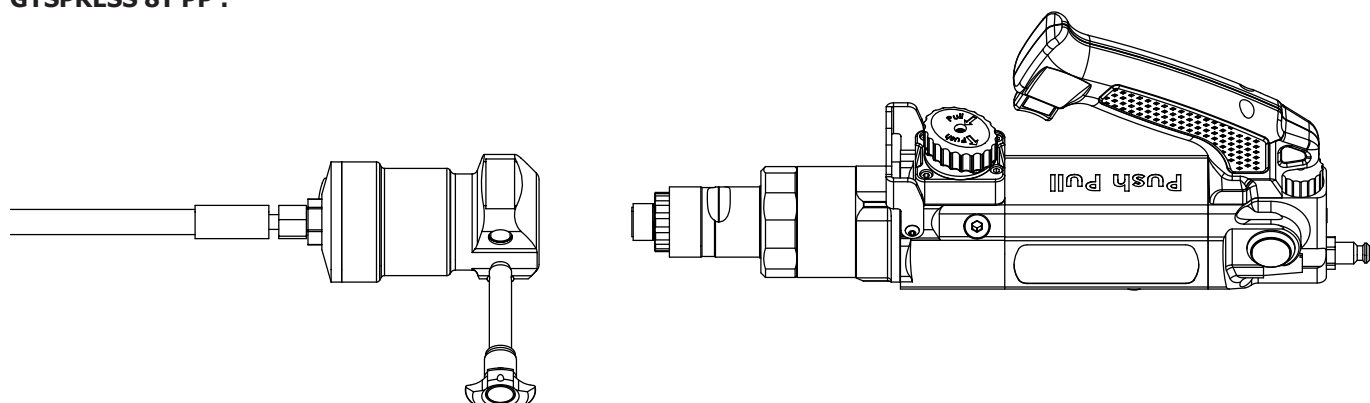

GYSPRESS 10T :

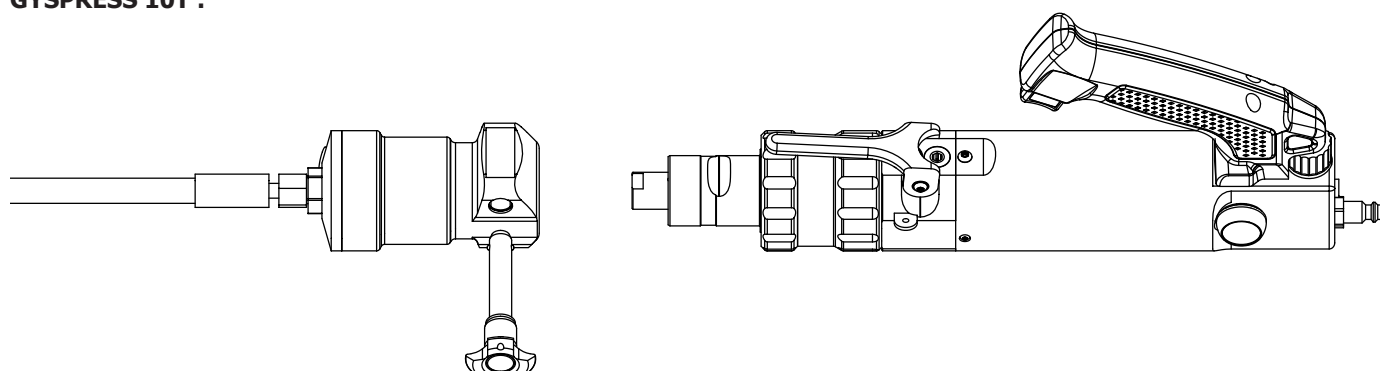

GYSPRESS 10T Connect :

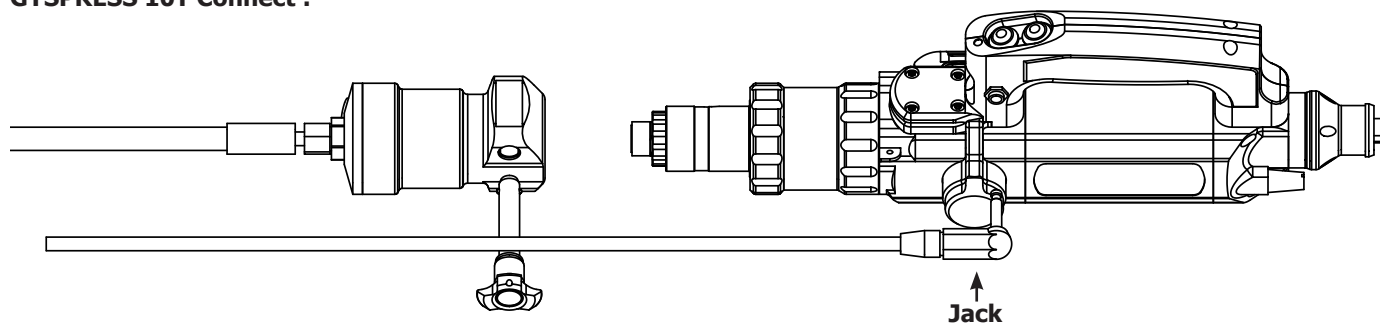

AJUSTES DEL ESFUERZO DEL ADAPTADOR

La fuerza de tracción del adaptador depende de la fuerza emitida por la remachadora:

Tabla de correspondencia con la fuerza proporcionada por la remachadora y la presión de aire en la entrada de la remachadora.

Presión de aire	2 bar / 29 Psi		3 bar / 44 Psi		4 bar / 58 Psi		5 bar / 72 Psi		6 bar / 87 Psi		6,5 bar / 94 Psi		7 bar / 101 Psi		8 bar / 116 Psi	
	Remachadora	Adaptador	Remachadora	Adaptador	Remachadora	Adaptador	Remachadora	Adaptador	Remachadora	Adaptador	Remachadora	Adaptador	Remachadora	Adaptador	Remachadora	Adaptador
GYPRESS 8T	20 kN	10 kN	30 kN	15 kN	40 kN	20 kN	50 kN	25 kN	60 kN	30 kN	65 kN	32,5 kN	70 kN	35 kN	80 kN	40 kN
GYPRESS 8T PP	20 kN	10 kN	30 kN	15 kN	40 kN	20 kN	50 kN	25 kN	60 kN	30 kN	65 kN	32,5 kN	70 kN	35 kN	80 kN	40 kN
GYPRESS 10T	29 kN	19,5 kN	44 kN	22 kN	58 kN	29 kN	72 kN	36 kN	87 kN	43,5 kN	100 kN	50 kN	100 kN	50 kN	100 kN	50 kN
GYPRESS 10T PP	29 kN	19,5 kN	44 kN	22 kN	58 kN	29 kN	72 kN	36 kN	87 kN	43,5 kN	100 kN	50 kN	100 kN	50 kN	100 kN	50 kN
GYPRESS 10T Connect	29 kN	19,5 kN	44 kN	22 kN	58 kN	29 kN	72 kN	36 kN	87 kN	43,5 kN	100 kN	50 kN	100 kN	50 kN	100 kN	50 kN

AJUSTES DE LA CARRERA

La carrera del adaptador es ajustable de 0 a 25 mm.
Se hace a través de la ruedecilla A.
Atornillela completamente para obtener 0 de carrera
Desatornillela completamente para obtener 25 mm de carrera

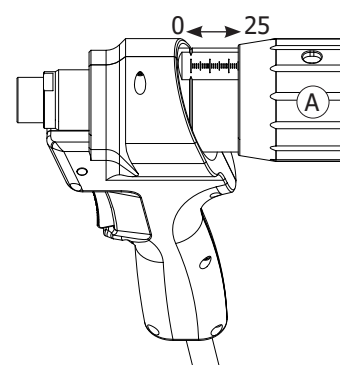

DIFERENTES KITS EN EL ADAPTADOR

Kit 1 :

Fijación de remaches ciegos para el diámetro de la varilla hasta 5 mm + extracción de remaches auto-perforantes.

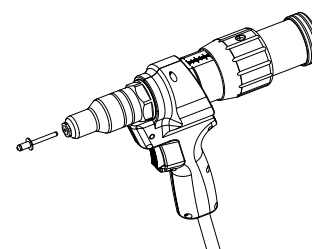

Kit 2 :

Fijación de tuercas y espárragos remachables M5 a M14.

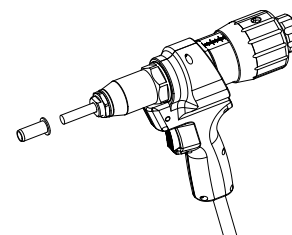

Kit 3 :

Extensión para fijar remaches ciegos para el diámetro de la varilla hasta 5 mm + extracción de remaches auto-perforantes.

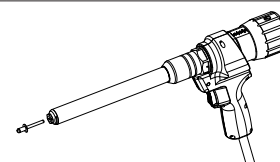

Kit 4 :

Fijación de remaches ciegos de Ø 9.8 mm.

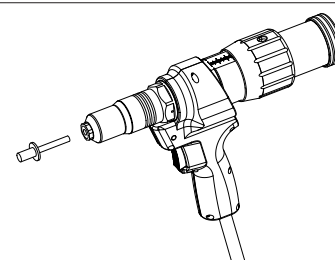

KIT 1

FIJACIÓN DE REMACHES CIEGOS PARA EL DIÁMETRO DE LA VARILLA HASTA 5 MM + EXTRACCIÓN DE REMACHES AUTO-PERFORANTES.

Orden de montaje del kit 1 :

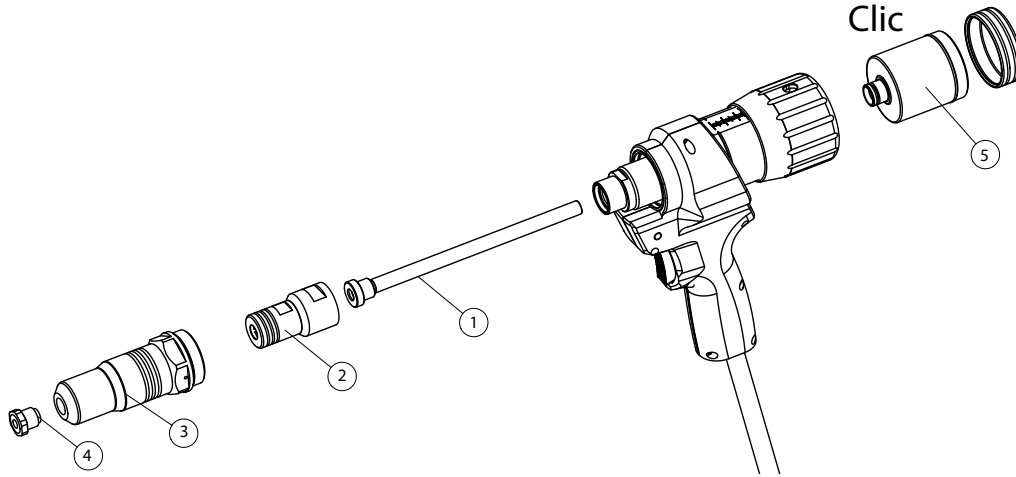

- 1- Inserte la tobera 1
- 2- Atornille el soporte de mordazas 2 con las 2 llaves (apriete bien)
- 3- Atornille el soporte de la boquilla 3 con las 2 llaves
- 4- Enrosque una de las boquillas adaptadas al remache que se va a fijar:

- Ø3.2 ref : 065994
- Ø3.5 ref : 066007
- Ø4.0 ref : 066014
- Ø4.5 ref : 066021
- Ø5.0 ref : 066038

Para facilitar la instalación de las boquillas :

- 1- Coloque un remache en la boquilla.
- 2- Inserte el remache con la boquilla en el soporte montado.
- 3- Apriete la boquilla con una llave de fijación.



Fijación de un remache ciego :

Fijación de un remache ciego :

Después de colocar la boquilla apropiada, coloque el remache hasta el tope de la boquilla 

Coloque el remache a través del agujero en las chapas que se van a remachar y presione el gatillo de la remachadora como se muestra a continuación:

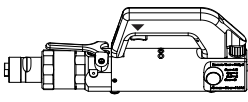
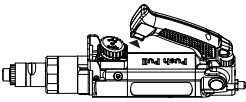
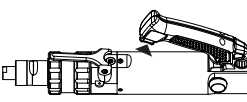
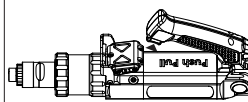
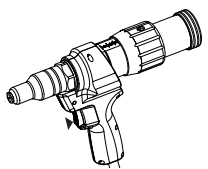
GYPRESS 8T	GYPRESS 8T PP	GYPRESS 10T	GYPRESS 10T PP	GYPRESS 10T Connect
				

Una vez que el remache esté puesto, suelte el gatillo. Para las remachadoras 8T y 10 T, presione el gatillo abajo.

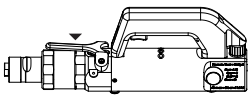
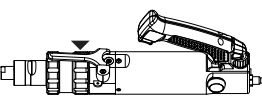
GYPRESS 8T	GYPRESS 10T
	

Al inclinar el adaptador hacia atrás, las varillas de remache caen en el tazón de recuperación.
Al inclinarse hacia adelante, las varillas salen por la boquilla.

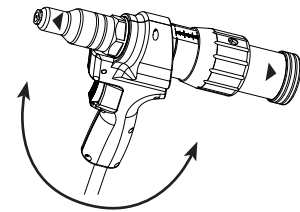

Recuperación de las varillas:

Para recuperar las varillas, quite la tapa del tazón.
Una vez que se recuperen las varillas, vuelve a poner la tapa hasta que haga clic.

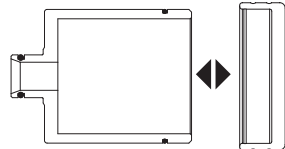

- 1- Tazón M0077
- 2- Tapa M0078
- 3- Junta tórica 55262
- 4- Junta tórica 55121

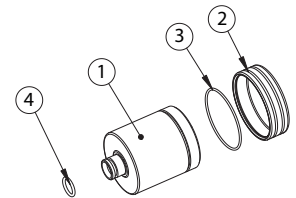

Reemplazo de las mordazas:

Desenrosque usando las llaves de fijación.
Vuelva a colocar las mordazas 2 y luego, colóquelas en 3 a 120°.
Coloque el 4, luego el 5 y luego enrosque el 1 con las llaves (apriete bien).



Llave de fijación

- 1- Conexión con mordazas M0042
- 2- Mordazas (ref. 058446) 51522
- 3- Cono mordazas M0043
- 4- Separador M0044
- 5- Resorte 55189

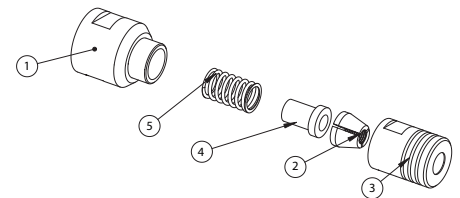

Extracción de remaches auto-perforantes (RAP)

El kit puede equiparse con una boquilla especial para la extracción de remaches auto-perforantes mediante la soldadura de una varilla al remache (ref. 066151).

Montaje de la boquilla :

Instale la boquilla de extracción 066151 en el soporte de la boquilla.

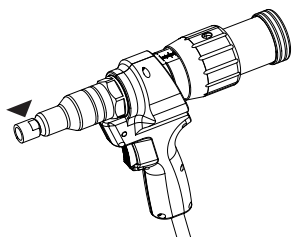

Ponga la tuerca de ajuste de la carrera a 15 mm.

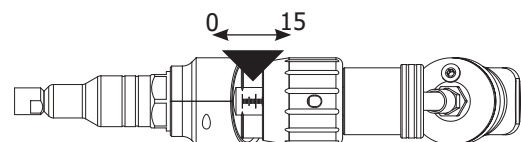

Pasos de la extracción :

1- Soldadura de la varilla de extracción :
Material: ARCPULL 350 062191 + ARC PULL RIVET BOX 064584

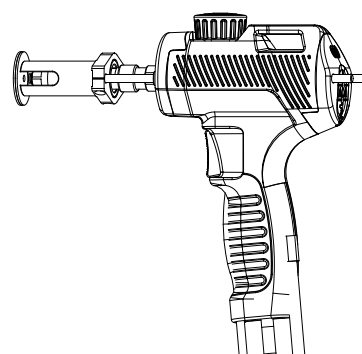
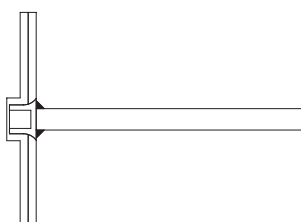

2- Inserte la varilla de extracción del remache hasta el final en la pistola, con la boquilla en contacto con la chapa:

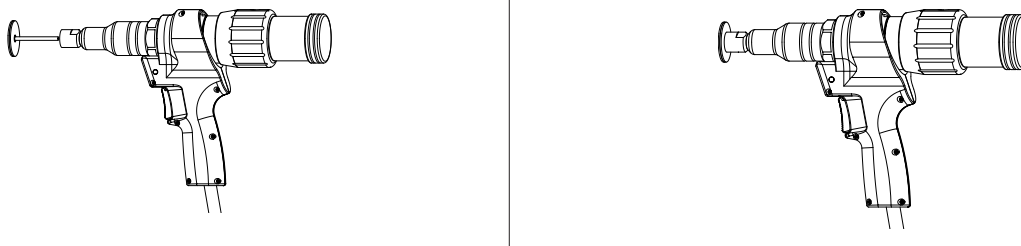

3- Active el adaptador de acuerdo con los modelos de abajo:

GYSPRESS 8T	GYSPRESS 8T PP	GYSPRESS 10T	GYSPRESS 10T PP	GYSPRESS 10T Connect

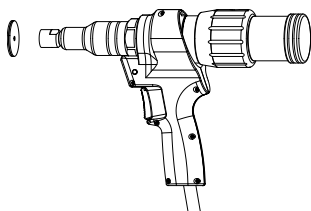

Una vez que se extrae el remache de la chapa, suelte el gatillo. Para las remachadoras de 8T y 10T, presione el gatillo de abajo:

GYSPRESS 8T	GYSPRESS 10T

El remache y la varilla salen en la parte delantera:

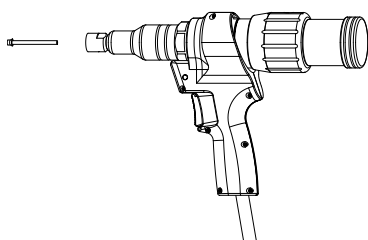

KIT 2

INSTALACIÓN DE TUERCAS Y ESPÁRRAGOS REMACHABLES M5 A M14..

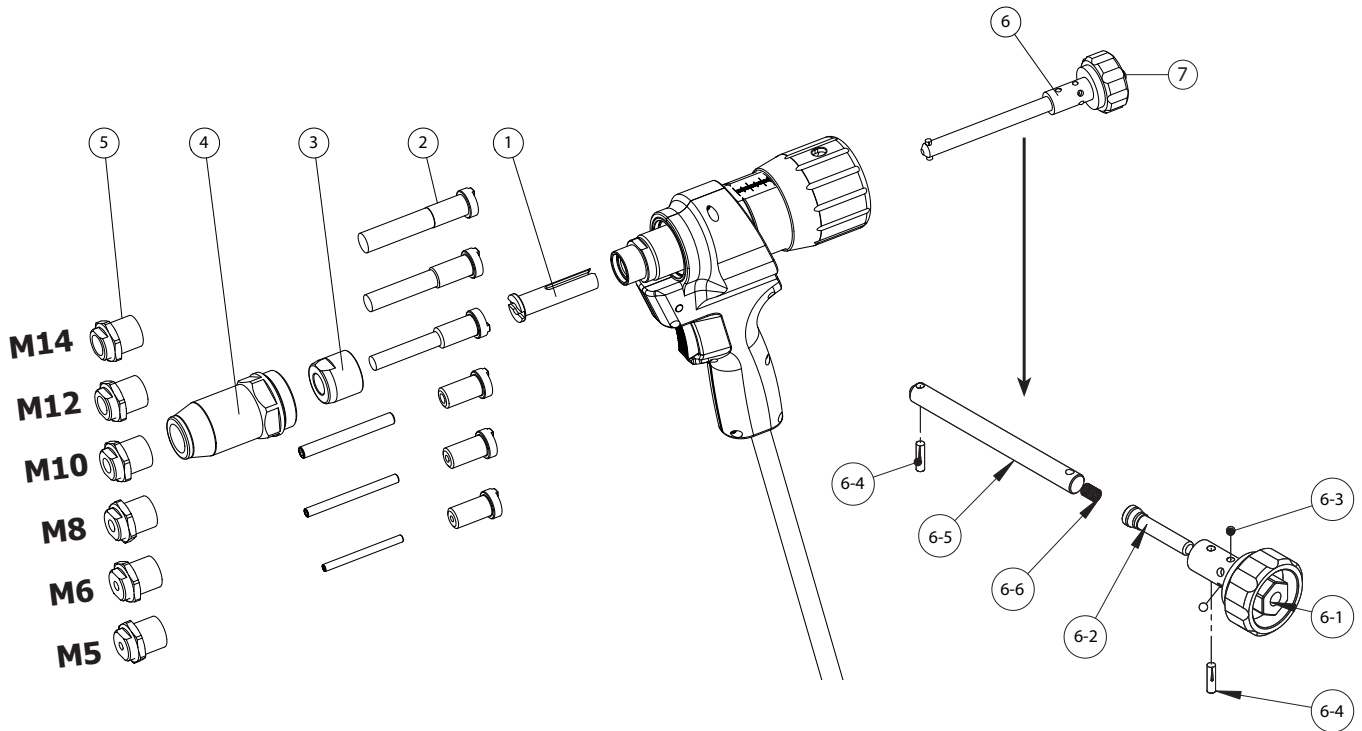

Orden de montaje del kit 2 :





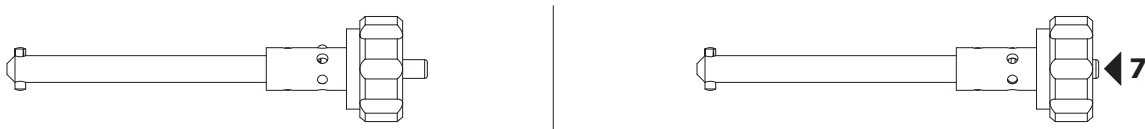



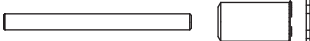

- 1- Ponga el conductor 1
- 2- Posicione el tornillo adaptado a la tuerca o al espárrago remachable (M5, M6, M8, M10, M12, M14)
- 3- Enrosque la tuerca de seguridad 3 con las 2 llaves de fijación (apriete bien)
- 4- Atornille el soporte de boquilla 4
- 5- Atornille la boquilla 5 adaptada a la tuerca o al espárrago remachable (M5, M6, M8, M10, M12, M14)
- 6- Posicione la ruedecilla motriz 6 (pulse el botón 7 para insertarla)

Para quitar la ruedecilla, presione el botón 7 y tire de la ruedecilla.

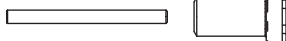
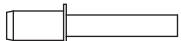

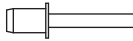
Par tornillo y boquilla según el inserto que se instale:

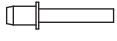
Tuerca de engaste M14		Boquilla M14		Varilla M14
Tuerca de engaste M12		Boquilla M12		Varilla M12
Tuerca de engaste M10		Boquilla M10		Varilla M10
Tuerca de engaste M8		Boquilla M8		Varilla M8 Tornillo M8

Tuerca de engaste M6		 Boquilla M6	 Varilla M6 Tornillo M6
Tuerca de engaste M5		 Boquilla M5	 Varilla M5 Tornillo M5
Espárragos remachables M8		 Boquilla M8	 Varilla M8
Espárragos remachables M6		 Boquilla M6	 Varilla M6
Espárragos remachables M5		 Boquilla M5	 Varilla M5

Colocación de tuercas de engaste.

ⓘ

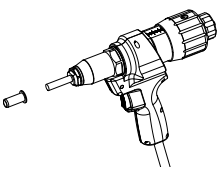
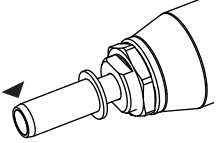
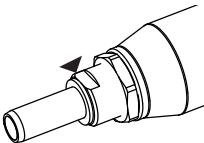
			Hay dos métodos para instalar las tuercas de engaste:
1.	2. Atornille la tuerca de engaste al menos hasta el final de la varilla.	3. Desenrosque la boquilla contra el inserto y apriete la contra-tuerca.	4. Ajuste para colocar las tuercas de engaste.

1 / Instalación a la presión

Dependiendo del tamaño de la tuerca de engaste, el esfuerzo requerido para la instalación varía. Reglas indicativas para la instalación de las tuercas de engaste (varía según el fabricante).

Esfuerzo de instalación recomendado por tamaño

Ø	Materia	Esfuerzo kN	Correspondencia remachadora 8T		Correspondencia remachadora 10T	
			Esfuerzo kN	Presión bar	Esfuerzo kN	Presión bar
M5	acier	8	16	1.6	16	1.1
M6	acier	12	24	2.4	24	1.6
M8	acier	18	36	3.6	36	2.5
M10	acier	21	42	4.2	42	3
M12	acier	23	46	4.6	46	3.2
M14	acier	50	-	-	100	6.5
M5	alu	3,8	7.6	0.8	7.6	0.5
M6	alu	5,5	11	1.1	11	0.75
M8	alu	10	20	2.0	20	1.5
M10	alu	12	24	2.4	24	1.6
M12	alu	15	30	3.0	30	2.0

Para la instalación a la presión, la carrera del adaptador puede ajustarse a 25 mm (máximo).

El ajuste del esfuerzo se hace con la remachadora. (ajuste con el botón y lectura de la presión).

1.1 / Opciones :

Lectura del manómetro.

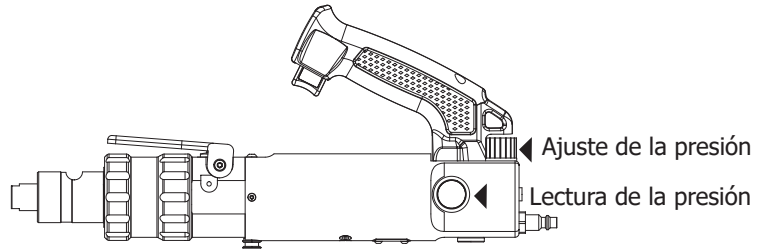

Lectura sobre el sensor de esfuerzo
(más preciso) solución a favorecer

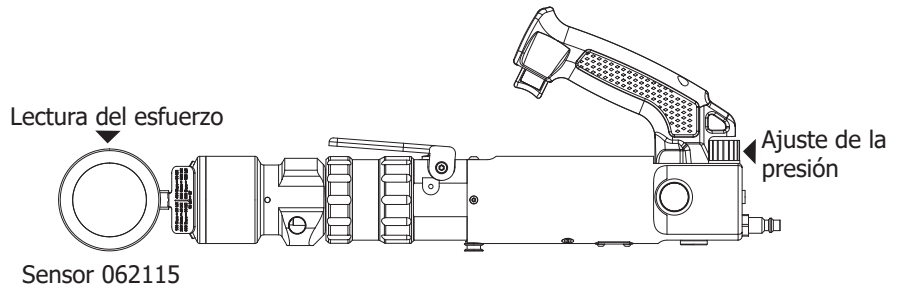

1.2 / Ejemplo

Tuerca de engaste M10 de acero para colocar con la remachadora 10T.

Ajuste de la carrera a 25 mm.

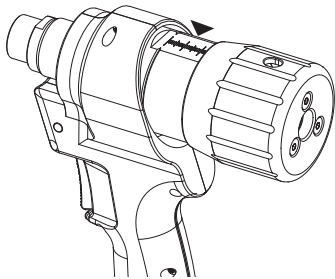

Ajuste de la remachadora con el sensor a 210 bares
que corresponden a 42 kN

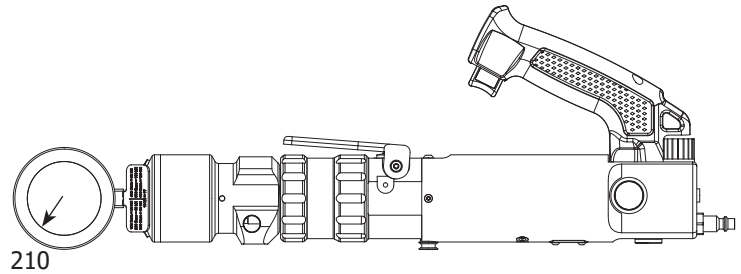

ou

Ajuste de la remachadora con el manómetro a 3
bares que corresponden a 42 kN.

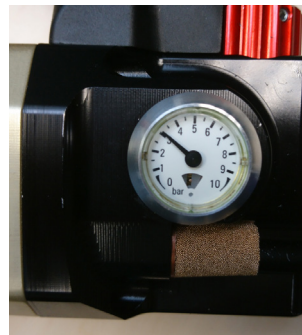

- Presione el control de la remachadora, y espere a que la remachadora se detenga.
- Suelte el gatillo y compruebe que el inserto está bien colocado.
- Si la tuerca de engaste no parece estar lo suficientemente engastada, aumente un poco el esfuerzo de la remachadora.
- Para quitar la varilla de tracción de la tuerca de engaste, desenrosque la ruedecilla trasera.

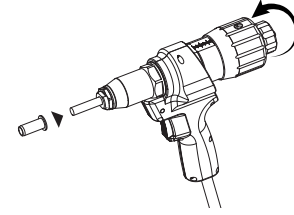

2/ Instalación a la carrera

1. Mida la dimensión interior de la tuerca de engaste (A)
2. Mida la dimensión del grosor de la brida (B)
3. Mida el grosor de la chapa que se utilizará para la tuerca de engaste (C).
4. Ajuste el resultado (D) en el adaptador con la fórmula:
 $D = A - B - C$

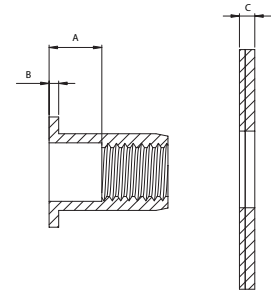
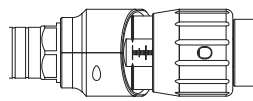

2.1 / Ejemplo :

Tuerca de engaste M12 / Chapa de grosor 2mm

1. Mida la dimensión interior de la tuerca de engaste (A) = 10.5mm
2. Mida la dimensión del grosor de la brida (B) = 2mm
3. Mida el grosor de la chapa que debe recibir el inserto (C) = 2mm
4. Ajuste el resultado en el adaptador
 $D = 10.5 - 2 - 2 = 6.5 \text{ mm}$

$$D = 10.5 - 2 - 2 = 6.5 \text{ mm}$$

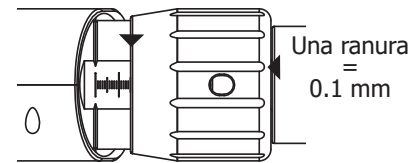

Para un ajuste más preciso, use la escala (en mm) y las ranuras en la ruedecilla. Una vuelta de la ruedecilla corresponde a 1,5 mm de carrera y hay 15 ranuras en la tuerca.

5. presione el control de la remachadora, y espere a que la remachadora se detenga.
6. Suelte el gatillo y compruebe que la tuerca de engaste está bien colocada.
7. Para quitar la varilla de tracción de la tuerca de engaste, desenrosque la ruedecilla trasera.

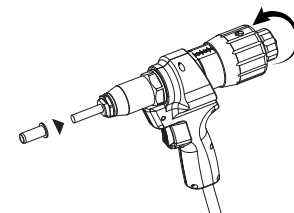

El ajuste incorrecto de la carrera de la herramienta puede llevar a un apriete incorrecto de las tuercas de engaste y a una rotura del tirante.

El ajuste de la carrera es esencial para fijar la tuerca de engaste.

Hay que tener en cuenta que una carrera excesiva puede provocar la rotura del tirante, mientras que una carrera insuficiente no garantiza la estabilidad de la tuerca de engaste.

Es preferible ir por etapas, aumentando la carrera a medida que se avanza.

3 / Colocación de espárragos remachables :

Para la colocación de espárragos remachables, no es posible una medición dimensional para la deformación.

Es preferible ir por etapas, aumentando la carrera a medida que se avanza.

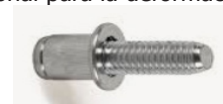

KIT 3

EXTENSIÓN PARA FIJAR REMACHES CIEGOS PARA EL DIÁMETRO DE LA VARILLA HASTA 5 MM + EXTRACCIÓN DE REMACHES AUTO-PERFORANTES.

Orden de montaje del kit 3 :

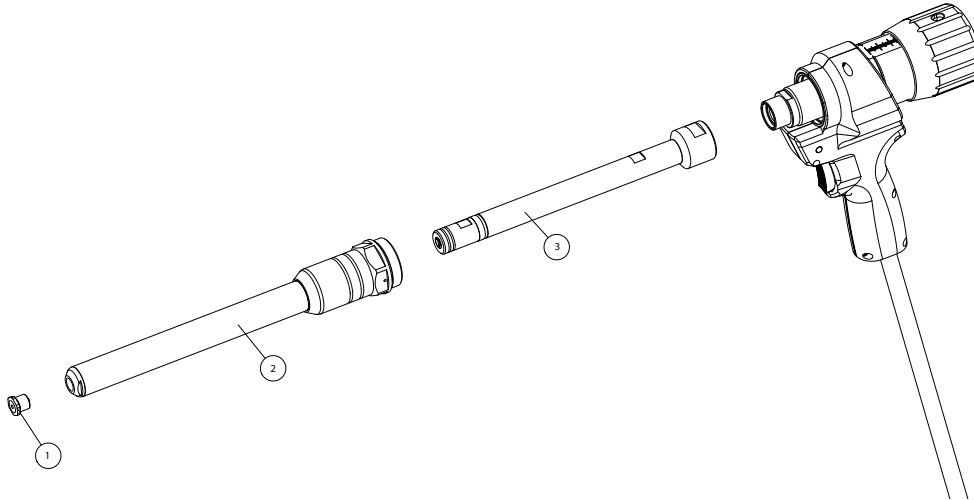

Para usar el kit de extensión no es necesario usar el tazón de recuperación de las varillas. Las varillas, una vez rotas, salen por el frente.

1. Atornille el soporte de mordazas 3 con 2 llaves de fijación (apriete bien)
2. Atornille el soporte de boquilla 2 con 2 llaves de fijación
3. Atornille una de las boquillas adaptadas al remache que se va a colocar (incluidas en el kit de base)

- Ø3.2 ref : 065994
- Ø3.5 ref : 066007
- Ø4.0 ref : 066014
- Ø4.5 ref : 066021
- Ø5.0 ref : 066038

Para facilitar la instalación de las boquillas :

- 1- Coloque un remache en la boquilla.
- 2- Inserte el remache con la boquilla en el soporte montado.
- 3- Apriete la boquilla con una llave de fijación.

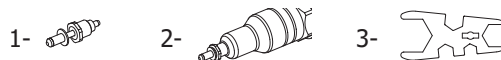

Fijación de un remache ciego :

Después de colocar la boquilla apropiada, coloque el remache hasta el tope de la boquilla 

Coloque el remache a través del agujero en las chapas que se van a remachar y presione el gatillo de la remachadora como se muestra a continuación:

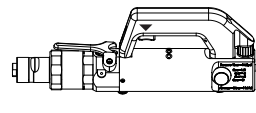
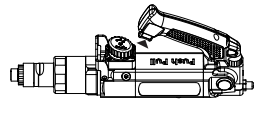
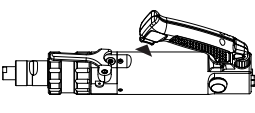
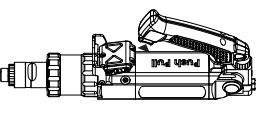
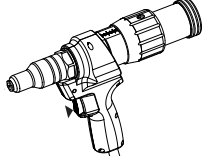
GYPRESS 8T	GYPRESS 8T PP	GYPRESS 10T	GYPRESS 10T PP	GYPRESS 10T Connect
				

Una vez que el remache esté puesto, suelte el gatillo. Para las remachadoras 8T y 10 T, presione el gatillo abajo.

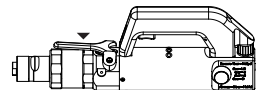
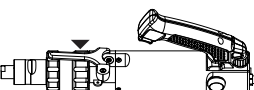
GYPRESS 8T	GYPRESS 10T
	

Al inclinar el adaptador hacia adelante, las varillas de remache salen de la boquilla.

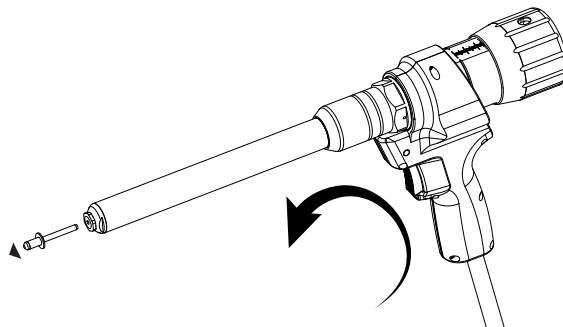

Reemplazo de las mordazas:

- 1- Conexión como mordazas M0042
- 2- Cono mordazas M0043
- 3- Mordazas 058446
- 4- Separador M0044
- 5- Resorte 55189
- 6- Extensión M0041
- 7- Empujador 93058
- 8- Resorte 55223
- 9- Junta 55133

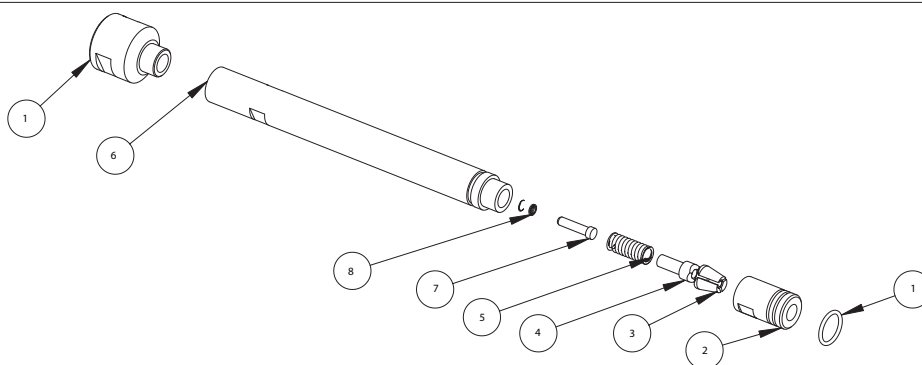

Desenrosque 2 usando las llaves de fijación

Vuelva a colocar las mordazas 3 y luego colóquelas en 3 a 120°.

Coloque sucesivamente el 4, 5, 7 y 8. Luego enrosque el 6 con las llaves (apriete bien).

Extracción de remaches autoperforantes : (ver el capítulo anterior)

KIT 4

FIJACIÓN DE REMACHES CIEGOS DE Ø 9.8

Orden de montaje del kit 4 :

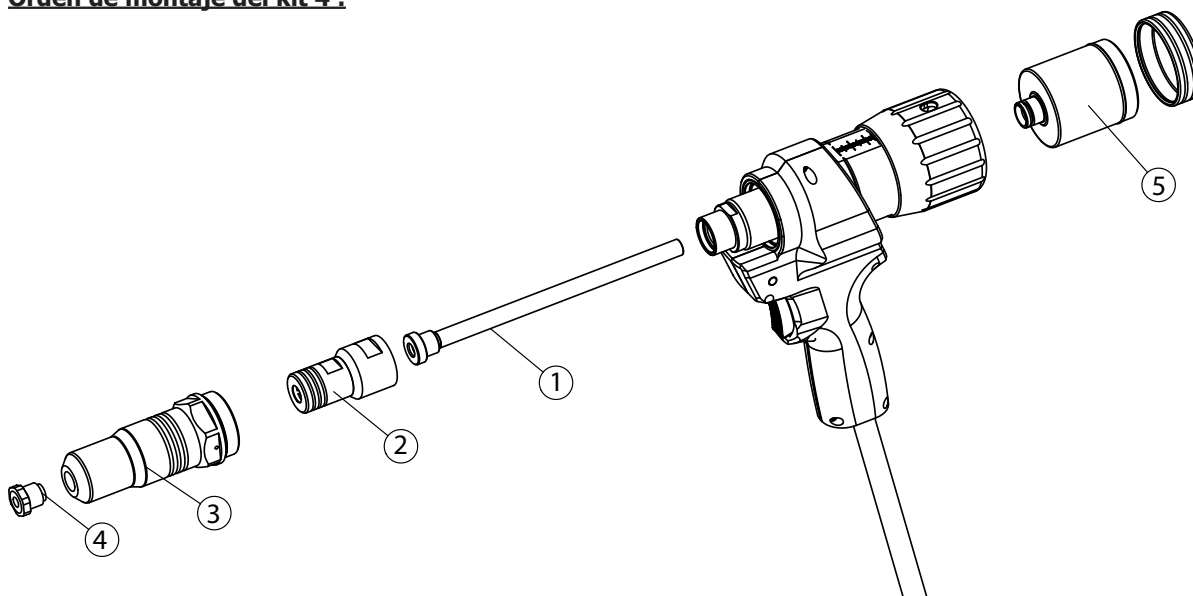

- 1- Coloque la tobera 1.
- 2 - Atornille el soporte de mordazas 2 con 2 llaves de fijación (apriete bien)
- 3- Atornille el soporte de boquilla 3 con 2 llaves de fijación
- 4- Atornille la boquilla de Ø6 ref : 066052.
- 5- Enhebre el tazón de recuperación 5



Para facilitar la instalación de las boquillas :

- 1- Coloque un remache en la boquilla.
- 2- Inserte el remache con la boquilla en el soporte montado.
- 3- Apriete la boquilla con una llave de fijación.



Fijación de un remache ciego :

Después de colocar la boquilla apropiada, coloque el remache hasta el tope de la boquilla

Coloque el remache a través del agujero en las chapas que se van a remachar y presione el gatillo de la remachadora como se muestra a continuación:

GYPRESS 8T	GYPRESS 8T PP	GYPRESS 10T	GYPRESS 10T PP	GYPRESS 10T Connect

Una vez que el remache esté puesto, suelte el gatillo. Para las remachadoras 8T y 10 T, presione el gatillo abajo.

GYPRESS 8T	GYPRESS 10T

Al inclinar el adaptador hacia atrás, las varillas de remache caen en el tazón de recuperación.
Al inclinarse hacia adelante, las varillas salen por la boquilla.

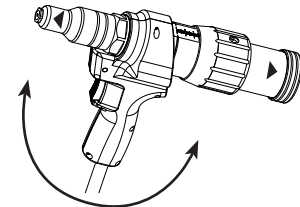

Recuperación de las varillas :

Para recuperar las varillas, quite la tapa del tazón.
Una vez que se recuperen las varillas, vuelve a poner la tapa hasta que haga clic.

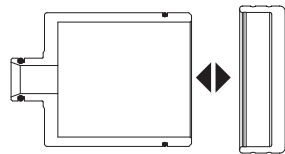

- 1- Tazón M0077
- 2- Tapa M0078
- 3- Junta tórica 55262
- 4- Junta tórica 55121

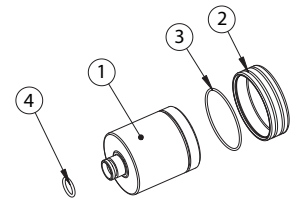

Reemplazo de las mordazas:

Desenrosque usando las llaves de fijación.
Vuelva a colocar las mordazas 2 y luego, colóquelas en 3 a 120°. Coloque el 4, luego el 5 y luego enrosque el 1 con las llaves (apriete bien).

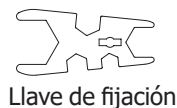

- 1- Conexión con mordazas M0042
- 2- Mordazas (ref. 058446) 51522
- 3- Cono mordazas M0043
- 4- Separador M0044
- 5- Resorte 55189

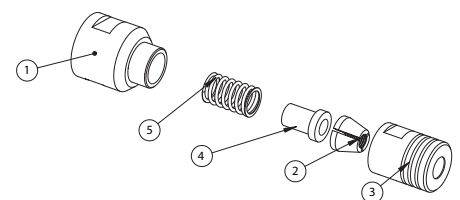

DESCRIZIONE

L'adattatore per rivetti ciechi è compatibile con le rivettatrici GYSPRESS 8T/10T e GYSPRESS 8T PUSH PULL. La sua forza di rivettatura è di 24 kN. Permette di posare dei rivetti ciechi di diametro da 4.0 a 7.8 mm per l'alluminio e da 4.0 a 6.4 mm per l'acciaio e per dadi e perni.

ISTRUZIONI DI SICUREZZA



- L'adattatore 50KN deve servire solamente per posare rivetti angolari ma anche dadi e perni.
- Equipaggiamento obbligatorio: occhiali di protezione, protezione acustica, guanti di sicurezza. Non puntare mai la punta dello strumento verso se stessi o qualcun altro.
- Non superare la pressione massima autorizzata di 7 bars.
- Utilizzare obbligatoriamente dei rivetti da posa angolari che seguino le specifiche
- Montare la punta in base alla dimensione del rivetto. Non usare mai la forza per posizionare il gambo del rivetto nella punta. Non utilizzare mai una punta più larga del gambo del rivetto.
- Verificare che il serraggio della parte da rivettare sia corretto.
- Tenere saldamente la rivettatrice finché il taglio nel gambo del rivetto non è completo e fuoriesce. Altrimenti, rilasciare il grilletto, quindi riprendere la trazione premendo di nuovo il grilletto,
- Scollegare sempre la macchina dopo ogni utilizzo e cambio della punta di rivettatura.
- Conservare questo manuale utente in un luogo sicuro. In caso di smarrimento, contattaci.

AMBIENTE

Questo dispositivo deve essere utilizzato solamente per fare delle operazioni di rivettatura nei limiti indicati sulla targhetta indicativa e/o sul manuale. Bisogna rispettare le direttive relative alla sicurezza. In caso di uso inadeguato o pericoloso, il fabbricante non potrà essere ritenuto responsabile.

Il dispositivo deve essere utilizzato in un locale senza polvere, né acido, né gas infiammabili o altre sostanze corrosive, e lo stesso vale per il suo stoccaggio. Assicurarsi che durante l'utilizzo ci sia una buona circolazione d'aria.

Intervallo di temperatura :

Utilizzo tra -10 e +40°C (+14 e +104°F).

Stoccaggio fra -20 e +55°C (-4 e 131°F).

Umidità dell'aria:

Inferiore o uguale a 50% a 40°C (104°F).

Inferiore o uguale a 90% a 20°C (68°F).

Altitudine :

Fino a 1000 m sopra il livello del mare (3280 piedi).

IN CASO DI GUASTO

L'operazione di rivettatura viene effettuata solo se si:

- Verifica che il dado di regolazione della corsa sia regolato al valore giusto.
- Verifica che la rivettatrice utilizzata funziona correttamente.
- Verifica che non ci siano delle perdite d'olio o di aria compressa.

ISTRUZIONI PER LA MANUTENZIONE

- Mantenere l'utensile in condizioni di pulizia. Controllare periodicamente il buono stato dei collegamenti dell'aria compressa, il corretto funzionamento dell'adattatore da 50 kN (il gioco naturale tra il gambo del rivetto e il bit).
- In caso di perdita d'olio, rimuovere il rivettatore e capovolgere l'utensile.
- Sostituzione delle ganasce (vedi pag. 46)

RICAPITOLATIVO

Rivettatrici	Potenza
GYSPRESS 8T	40 kN
GYSPRESS 8T PP	40 kN
GYSPRESS 10T	50 kN
GYSPRESS 10T PP	50 kN
GYSPRESS 10T Connect	50 kN

MONTAGGIO SU GYSPRESS

GYSPRESS 8T :

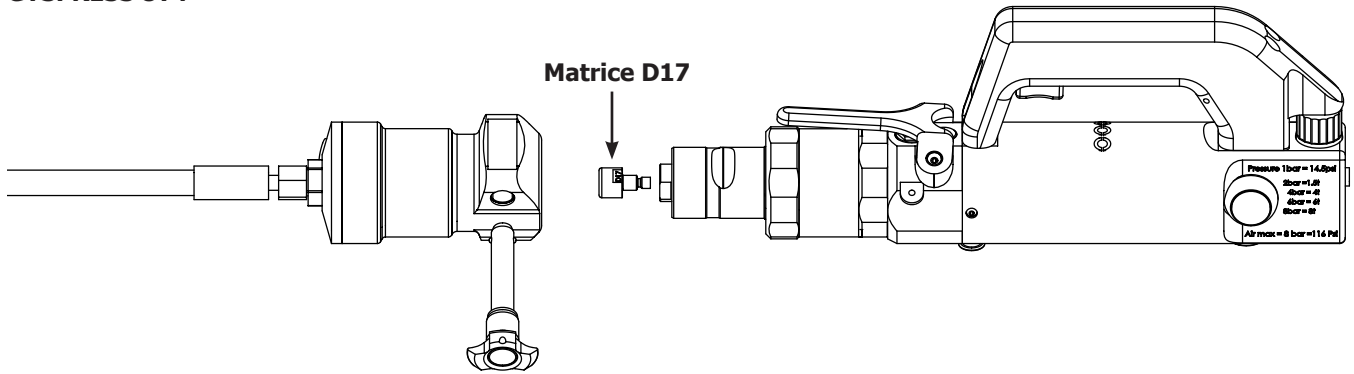

GYSPRESS 8T PP :

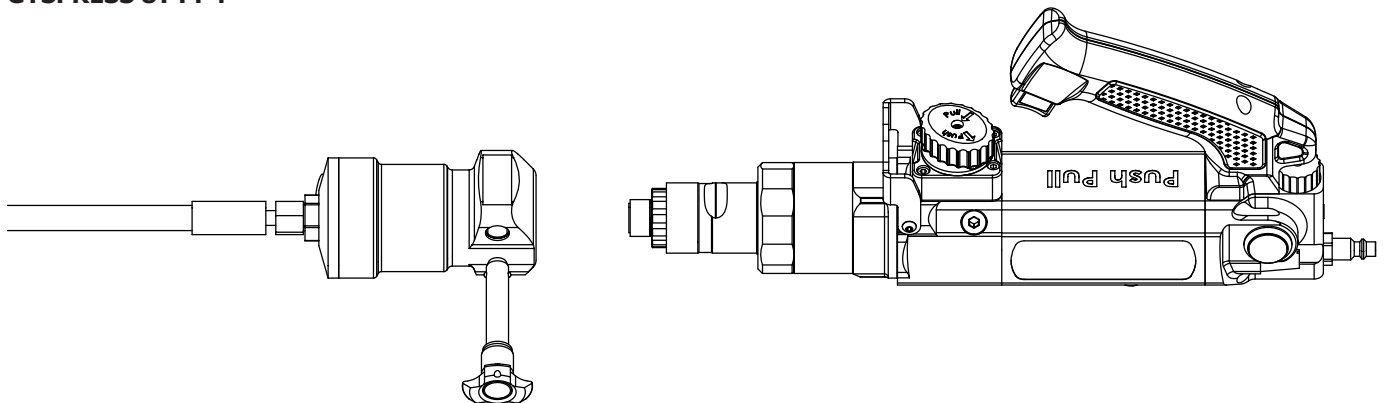

GYSPRESS 10T :

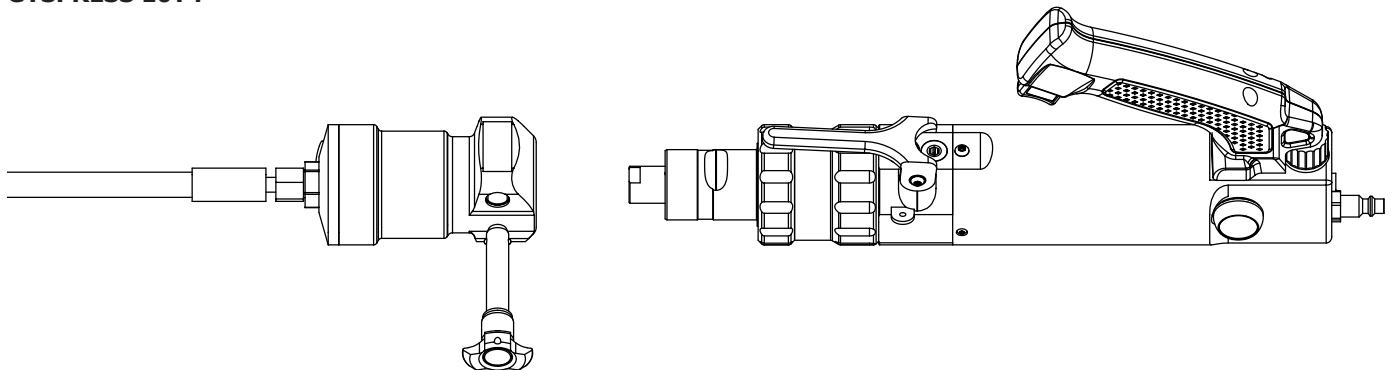

GYSPRESS 10T Connect :

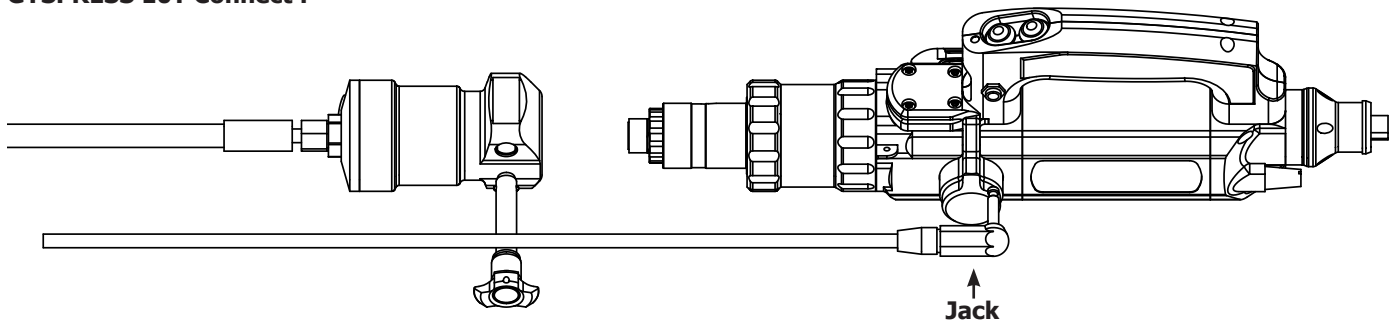

REGOLAZIONI DELLO SFORZO DELL'ADATTATORE

Lo sforzo di trazione dell'adattatore dipende dallo sforzo emesso dalla rivettatrice:

Tabella di corrispondenza con lo sforzo fornito dalla rivettatrice e della pressione dell'aria in entrata della rivettatrice.

Pressione d'aria	2 bar / 29 Psi		3 bar / 44 Psi		4 bar / 58 Psi		5 bar / 72 Psi		6 bar / 87 Psi		6,5 bar / 94 Psi		7 bar / 101 Psi		8 bar / 116 Psi	
	Rivettatrice	Adattatore	Rivettatrice	Adattatore	Rivettatrice	Adattatore	Rivettatrice	Adattatore	Rivettatrice	Adattatore	Rivettatrice	Adattatore	Rivettatrice	Adattatore	Rivettatrice	Adattatore
GYPESPRESS 8T	20 kN	10 kN	30 kN	15 kN	40 kN	20 kN	50 kN	25 kN	60 kN	30 kN	65 kN	32,5 kN	70 kN	35 kN	80 kN	40 kN
GYPESPRESS 8T PP	20 kN	10 kN	30 kN	15 kN	40 kN	20 kN	50 kN	25 kN	60 kN	30 kN	65 kN	32,5 kN	70 kN	35 kN	80 kN	40 kN
GYPESPRESS 10T	29 kN	19,5 kN	44 kN	22 kN	58 kN	29 kN	72 kN	36 kN	87 kN	43,5 kN	100 kN	50 kN	100 kN	50 kN	100 kN	50 kN
GYPESPRESS 10T PP	29 kN	19,5 kN	44 kN	22 kN	58 kN	29 kN	72 kN	36 kN	87 kN	43,5 kN	100 kN	50 kN	100 kN	50 kN	100 kN	50 kN
GYPESPRESS 10T Connect	29 kN	19,5 kN	44 kN	22 kN	58 kN	29 kN	72 kN	36 kN	87 kN	43,5 kN	100 kN	50 kN	100 kN	50 kN	100 kN	50 kN

REGOLAZIONI DELLA CORSA

La corsa dell'adattatore è regolabile da 0 a 25 mm.
Si fa tramite la manopola A.
Stringere completamente per avere 0 di corsa.
Svitare completamente per avere 25 mm di corsa.

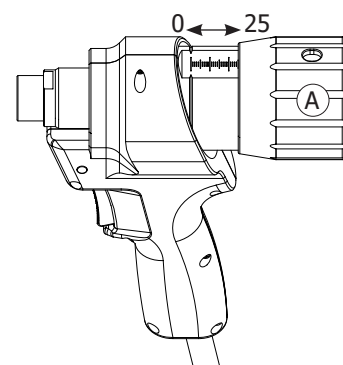

DIVERSI KIT SULL'ADATTATORE

Kit 1 :

Posa di rivetti angolari a seconda del diametro dell'asta fino a 5 mm + estrazione del rivetto auto-perforante.

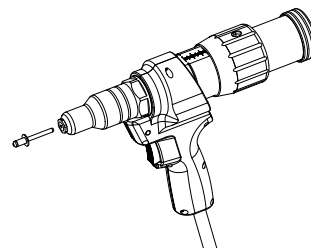

Kit 2 :

Posa di dadi e di perni M5 a M14.

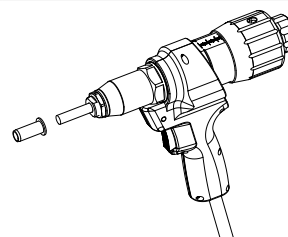

Kit 3 :

Prolunga per la posa di rivetti angolari a seconda del diametro dell'asta fino a 5mm + estrazione del rivetto auto-perforante.

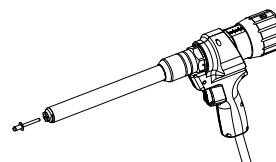

Kit 4 :

Posa di rivetti angolari \varnothing 9.8 mm.

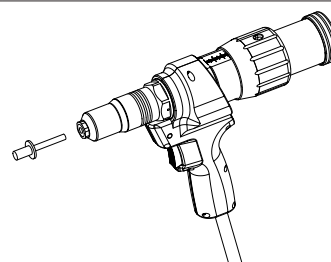

KIT 1

**POSA DI RIVETTI ANGOLARI A SECONDA DEL DIAMETRO DELL'ASTA FINO A 5 MM +
ESTRAZIONE DEL RIVETTO AUTO-PERFORANTE.**

Ordine del montaggio del kit 1 :

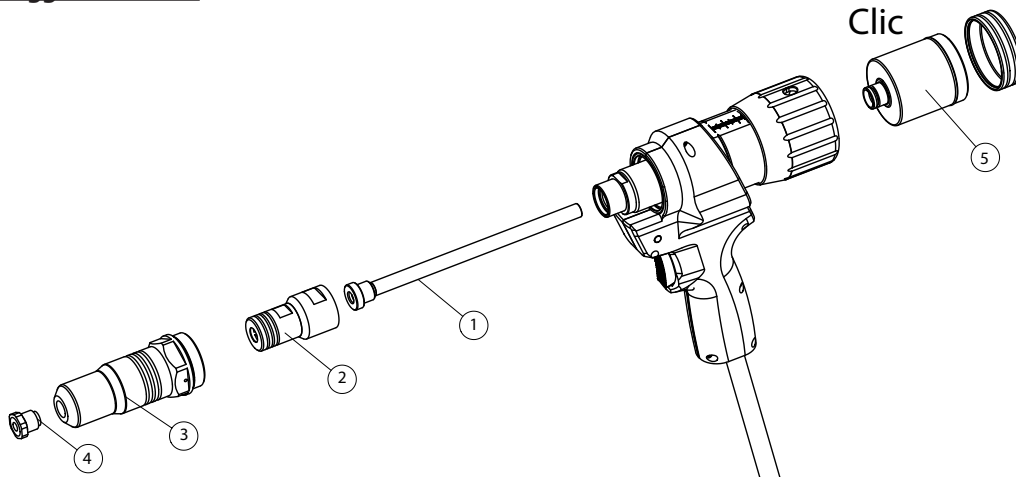

- 1- Mettere l'ugello 1
- 2- Avvitare il supporto morsi 2 con le 2 chiavi di serraggio (stringere bene)
- 3- Avvitare il supporto ugello 3 con le 2 chiavi di serraggio
- 4- Avvitare un ugello adatto al rivetto da posizionare:

- Ø3.2 ref : 065994
- Ø3.5 ref : 066007
- Ø4.0 ref : 066014
- Ø4.5 ref : 066021
- Ø5.0 ref : 066038

- Per facilitare il posizionamento degli ugelli:
- 1- Posizionare un rivetto nell'ugello.
 - 2- Inserire il rivetto con l'ugello nel supporto montato.
 - 3- Stringere l'ugello con una chiave di serraggio.



- 5- Infilare il recipiente di recupero

Posa di un rivetto angolare:

Dopo aver montato l'ugello corretto, posizionare il rivetto fino all'arresto dell'ugello 

Posizionare il rivetto attraverso il foro delle lamiera da rivettare e premere il grilletto della rivettatrice secondo il modello sottostante :

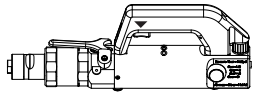
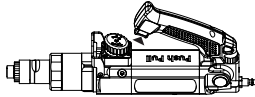
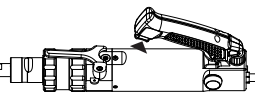
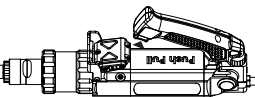
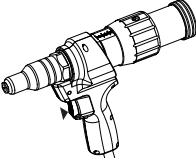
GYPRESS 8T	GYPRESS 8T PP	GYPRESS 10T	GYPRESS 10T PP	GYPRESS 10T Connect
				

Una volta che il rivetto è scattato, rilascia il grilletto. Per rivettatrici 8T e 10T premere il grilletto sotto.

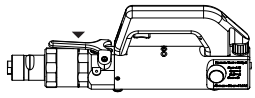
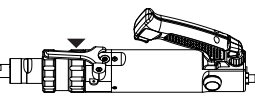
GYPRESS 8T	GYPRESS 10T
	

Quando si inclina l'adattatore all'indietro, i gambi dei rivetti cadono nel recipiente di raccolta.
Sporgendosi in avanti, le aste escono dall'ugello.

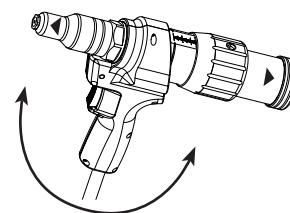

Recupero delle aste:

Per raccogliere le aste, tirare verso l'alto il coperchio del recipiente.
Una volta raccolte le aste, riposizionare il coperchio finché non scatta.

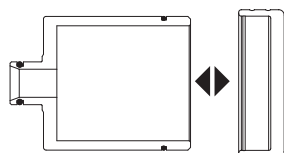

- 1- Recipiente M0077
- 2- Coperchio M0078
- 3- Anello toroidale 55262
- 4- Anello toroidale 55121

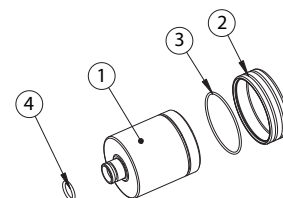

Sostituzione dei morsi:

Svitare utilizzando le chiavi di serraggio.
Sostituire i morsi 2 e poi, posizionarli da 3 a 120°.
Posizionare 4 poi 5 e poi avvitare 1 usando le chiavi (stringere bene).



Chiave di serraggio

- 1- Collegamento con morsi M0042
- 2- Morsi (rif. 058446) 51522
- 3- Cono morsi M0043
- 4- Distanziatore M0044
- 5- Molla 55189

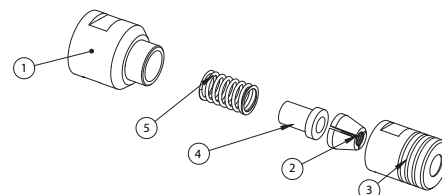

Estrazione di un rivetto auto-perforante:

Il kit può essere dotato di un ugello speciale per l'estrazione dei rivetti auto-perforanti mediante saldatura di un'asta al rivetto (rif. 066151).

Montaggio dell'ugello:

Montare l'ugello di estrazione 066151 sul supporto dell'ugello.

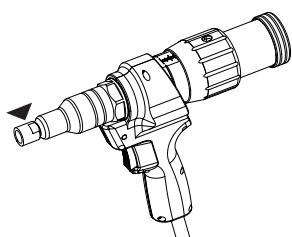

Regolare il dado di regolazione con corsa su 15 mm.

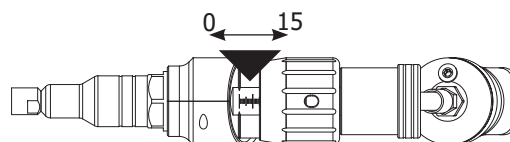

Tappe di estrazione:

1- Saldatura dell'asta di estrazione:
Materiale: ARC PULL 350 062191 + ARC PULL RIVET BOX 064584

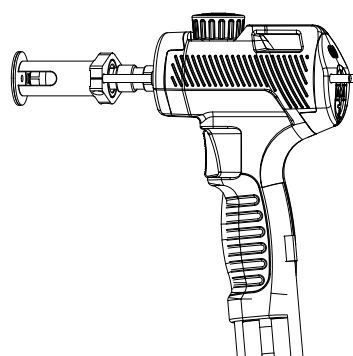
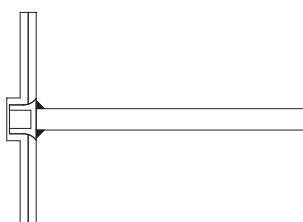

2- Inserire l'asta di estrazione del rivetto fino in fondo nella pistola, l'ugello a contatto con la lamiera:

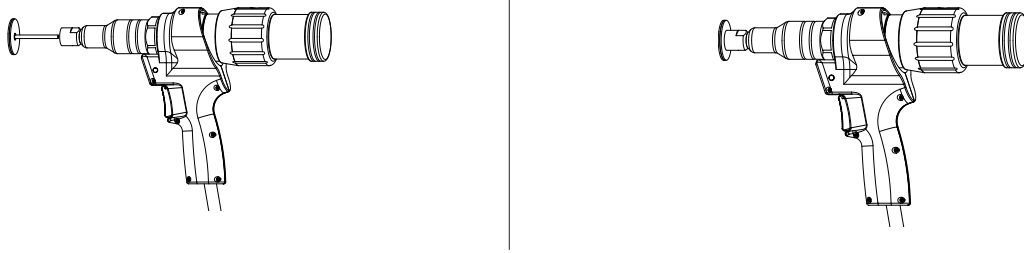

3- Azionare l'adattatore secondo il seguente modello:

GYPESPRESS 8T	GYPESPRESS 8T PP	GYPESPRESS 10T	GYPESPRESS 10T PP	GYPESPRESS 10T Connect

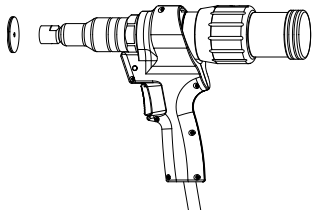

Una volta che il rivetto è estratto nella lamiera, rilasciare il grilletto. Per le rivettatrici 8T e 10T, premere sul grilletto come qui di seguito:

GYPESPRESS 8T	GYPESPRESS 10T

Il rivetto e l'asta escono dal davanti:

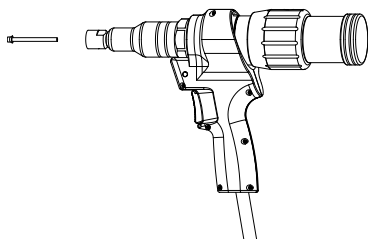

KIT 2

POSA DI DADI E DI PERNI M5 A M14.

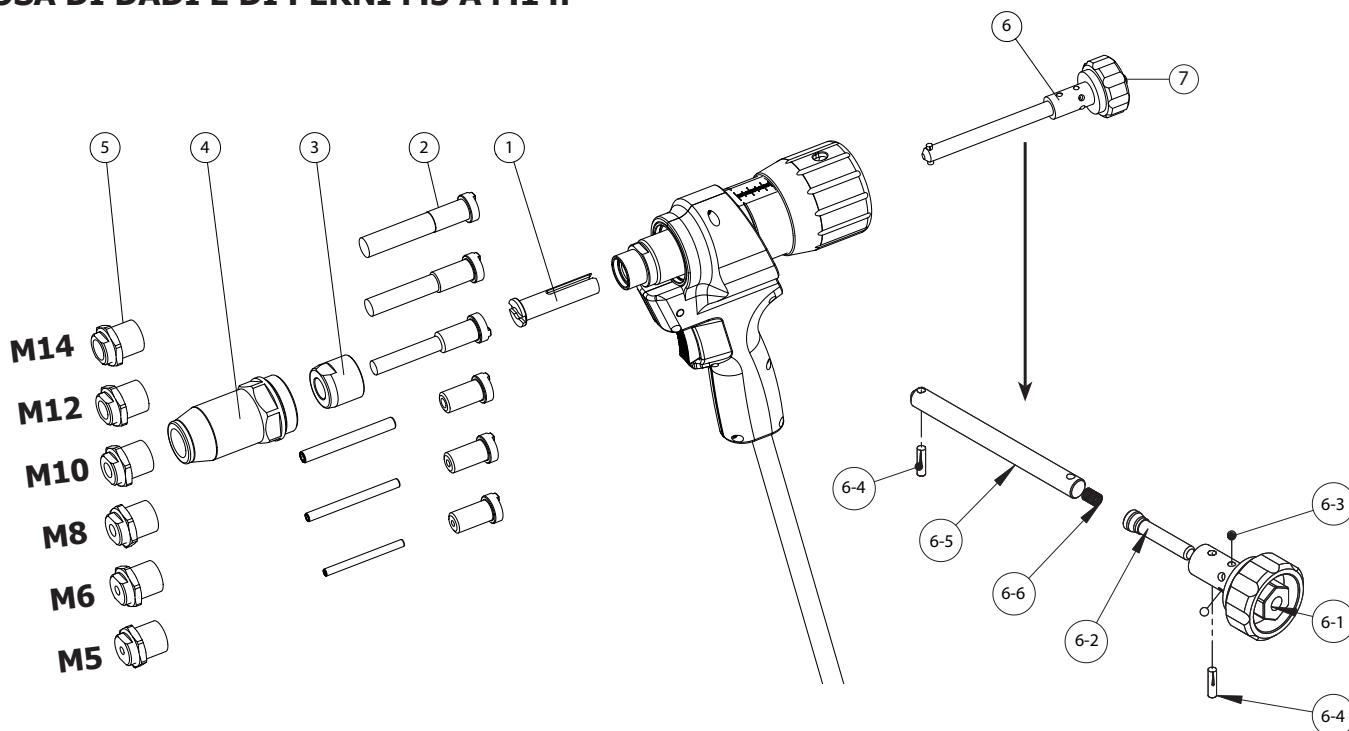

Ordine del montaggio del kit 2:





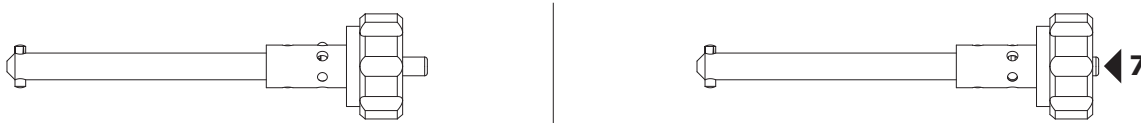



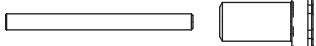

- 1- Mettere il porta-utensili 1
- 2- Posizionare la vite adatta al dado o al perno di crimpatura (M5, M6, M8, M10, M12, M14)
- 3- Avvitare il dado di bloccaggio 3 con le 2 chiavi di serraggio (stringere bene)
- 4- Avvitare il supporto dell'ugello 4
- 5- Avvitare l'ugello 5 adatto al dado o al perno di crimpatura (M5, M6, M8, M10, M12, M14)
- 6- Posizionare la manopola di trascinamento 6 (premere il pulsante 7 per inserirla)

Per rimuovere la manopola, premere il pulsante 7 e tirare la manopola

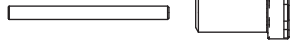

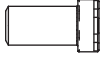
Coppia di viti e ugelli a seconda dell'inserito da montare:

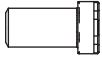
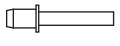
Dado M14		Ugello M14		Asta M14
Dado M12		Ugello M12		Asta M12
Dado M10		Ugello M10		Asta M10
Dado M8		Ugello M8		Asta M8 Vite M8

Dado M6		 Ugello M6	 Asta M6 Vite M6
Dado M5		 Ugello M5	 Asta M5 Vite M5
Perno M8		 Ugello M8	 Asta M8
Perno M6		 Ugello M6	 Asta M6
Perno M5		 Ugello M5	 Asta M5

Posa di un dado:

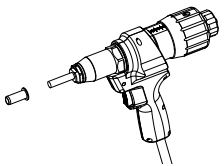
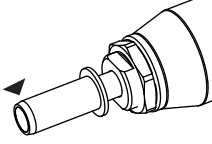
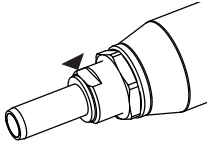
			Ci sono due metodi per posare i dadi di crimpatura:
1.	2. Avvitare il dado almeno fino all'estremità dell'asta.	3. Svitare l'ugello contro l'inserto e serrare il dado.	4. Regolazione per la posa dei dadi.

1 / Posa alla pressione

A seconda delle dimensioni del dado per rivetti ciechi, la forza richiesta per l'installazione varia. Regole indicative per il montaggio dei dadi (varia a seconda del costruttore).

Sforzo di installazione raccomandata a seconda della dimensione

Ø	Materiale	Sforzo kN	Corrispondenza rivettatrice 8T		Corrispondenza rivettatrice 10T	
			Sforzo kN	Pressione bar	Sforzo kN	Pressione bar
M5	acier	8	16	1.6	16	1.1
M6	acier	12	24	2.4	24	1.6
M8	acier	18	36	3.6	36	2.5
M10	acier	21	42	4.2	42	3
M12	acier	23	46	4.6	46	3.2
M14	acier	50	-	-	100	6.5
M5	alu	3,8	7.6	0.8	7.6	0.5
M6	alu	5,5	11	1.1	11	0.75
M8	alu	10	20	2.0	20	1.5
M10	alu	12	24	2.4	24	1.6
M12	alu	15	30	3.0	30	2.0

Per la posa a pressione, la corsa dell'adattatore può essere regolata a 25 mm (max). Lo sforzo viene regolato con la rivettatrice. (regolazione con il pulsante e lettura della pressione).

1.1 / Opzioni

Lettura del manometro.

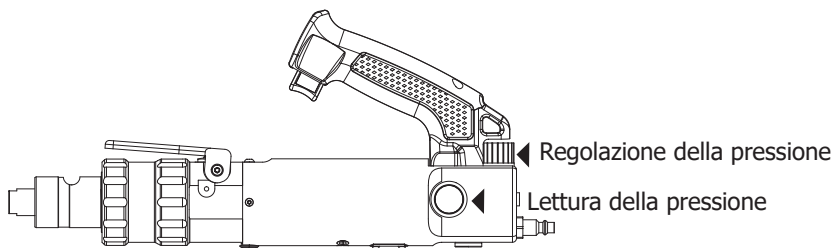

Lettura sul sensore di sforzo
(più precisa) soluzione da prediligere

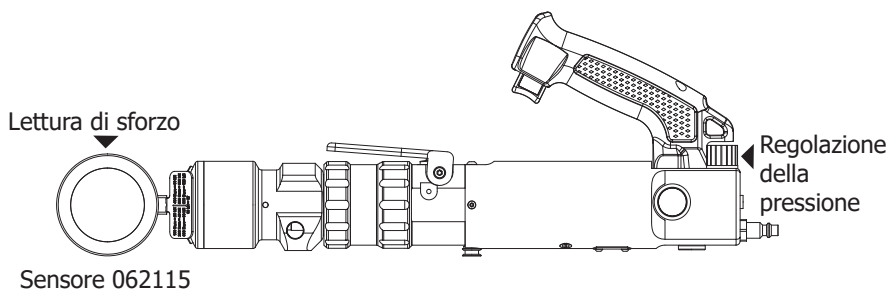

1.2 / Esempio

Dado M10 acciaio da posare con una rivettatrice 10T.

Regolazione della corsa su 25 mm.

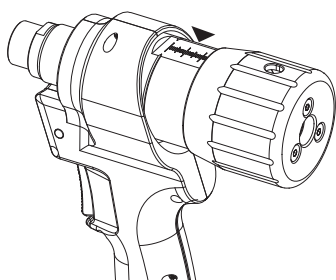

Regolazione della rivettatrice con sensore su 210 bars
che corrisponde a 42 kN.

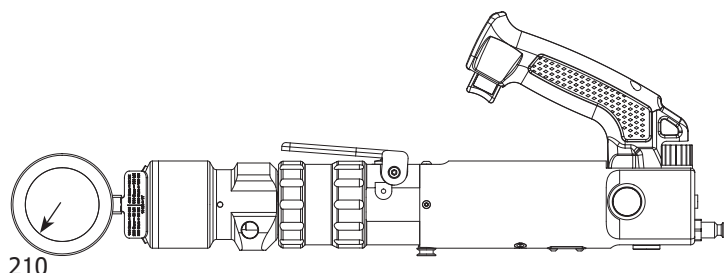

OU

Regolazione della rivettatrice con manometro 3
bars che corrisponde a 42 kN.

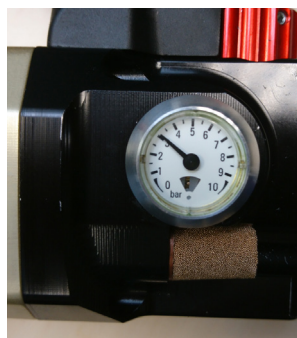

- Premere il comando della rivettatrice e attendere che si fermi.
- Rilasciare il grilletto e verificare che l'inserto sia posizionato correttamente.
- Se il dado del rivetto non sembra essere abbastanza stretto, aumentare leggermente la forza della rivettatrice.
- Per rimuovere l'asta dal dado del rivetto, svtarlo utilizzando la manopola posteriore.

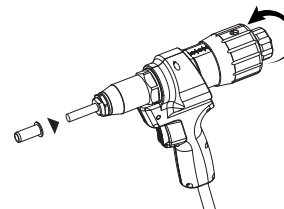

2/ Posa alla corsa

1. Misurare la dimensione interna del dado(A)
2. Misurare la dimensione dello spessore della flangia(B)
3. Misurare lo spessore della lamiera che deve ricevere il dado (C)
4. Regolare sull'adattatore il risultato ottenuto (D) con la formula:
 $D = A - B - C$

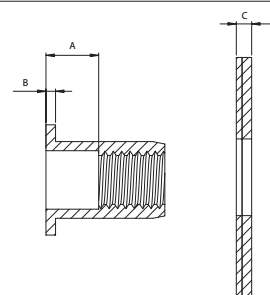
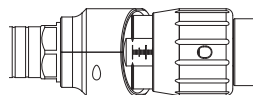

2.1 / Esempio :

Dado M12 / Spessore lamiera 2mm

1. Misurare la dimensione interna del dado(A) = 10.5 mm
2. Misurare la dimensione dello spessore della flangia(B) = 2 mm
3. Misurare lo spessore della lamiera che deve ricevere il dado (C) = 2 mm
4. Regolare sull'adattatore il risultato ottenuto (D) con la formula:
 $D = 10.5 - 2 - 2 = 6.5 \text{ mm}$

$$D = 10.5 - 2 - 2 = 6.5 \text{ mm}$$

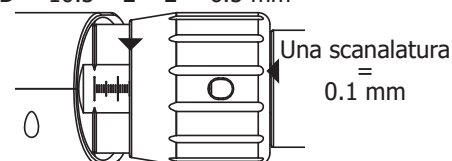

Per una regolazione più precisa, utilizzare la graduazione (in mm) e le scanalature sulla manopola.

Un giro del quadrante ha una corsa di 1,5 mm e sul dado sono presenti 15 scanalature.

5. premere il comando della rivettatrice e attendere che si fermi.
6. Rilasciare il grilletto e controllare che il dado del sia posizionato correttamente.
7. Per rimuovere l'asta di trazione dal dado, svitare con l'aiuto della manopola posteriore.

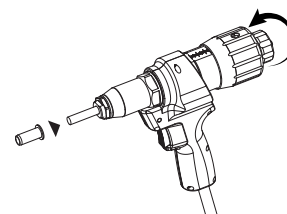

Una regolazione errata della corsa dell'utensile, può portare a un serraggio improprio dei dadi e alla rottura del tirante.

La regolazione della corsa è essenziale per fissare il dado.

Va considerato che una corsa eccessiva può causare la rottura del tirante, mentre una corsa insufficiente non garantisce la stabilità del dado.

È meglio farlo passo dopo passo, aumentando la corsa poco a poco.

3 / Posa dei perni:

Per l'installazione dei perni non è possibile una misurazione dimensionale della deformazione.

È meglio andare passo dopo passo, aumentando la corsa man mano.

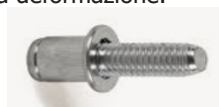

KIT 3

**PROLUNGA PER LA POSA DI RIVETTI ANGOLARI A SECONDA DEL DIAMETRO DELL'ASTA
FINO A 5MM + ESTRAZIONE DEL RIVETTO AUTO-PERFORANTE**

Ordine del montaggio del kit 3:

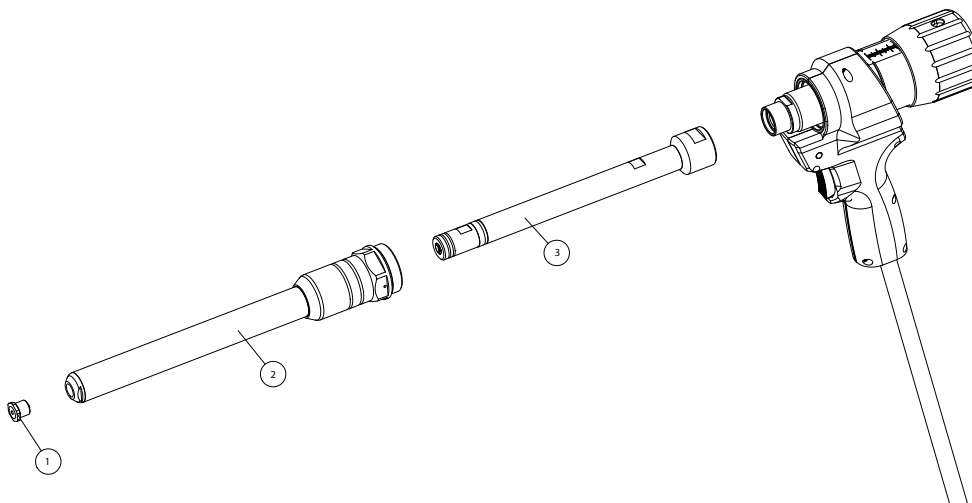

Per utilizzare il kit prolunga non è necessario utilizzare il recipiente per la raccolta delle aste.
Le aste, quando rotte, fuoriescono sul davanti.

1. Avvitare il supporto dei morsi 3 con le 2 chiavi di serraggio (stringere bene)
2. Avvitare il supporto ugello 2 con le 2 chiavi di serraggio
3. Avvitare un ugello adatto al rivetto da posizionare (compreso nel kit base)

- Ø3.2 ref : 065994
- Ø3.5 ref : 066007
- Ø4.0 ref : 066014
- Ø4.5 ref : 066021
- Ø5.0 ref : 066038

Per facilitare il posizionamento degli ugelli:

- 1- Posizionare un rivetto nell'ugello.
- 2- Inserire il rivetto con l'ugello nel supporto montato.
- 3- Stringere l'ugello con una chiave di serraggio.



Posa di un rivetto angolare:

Dopo aver montato l'ugello corretto, posizionare il rivetto fino all'arresto dell'ugello

Posizionare il rivetto attraverso il foro delle lamiere da rivettare e premere il grilletto della rivettatrice secondo il modello sottostante :

GYPRESS 8T	GYPRESS 8T PP	GYPRESS 10T	GYPRESS 10T PP	GYPRESS 10T Connect

Una volta che il rivetto è scattato, rilascia il grilletto. Per rivettatrici 8T e 10T premere il grilletto come in seguito.

GYPRESS 8T	GYPRESS 10T

Inclinando in avanti l'adattatore, i gambi dei rivetti fuoriescono dall'ugello.

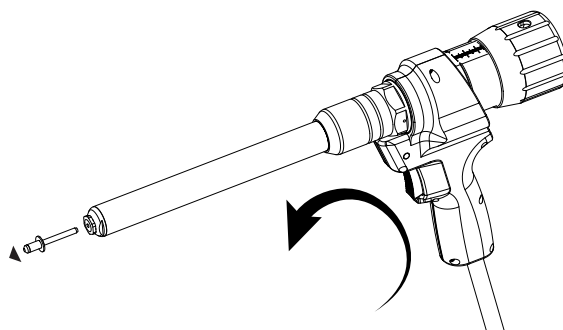

Sostituzione dei morsi:

- 1-Collegamento con morsi M0042
- 2- Cono morsi M0043
- 3- Morsi 058446
- 4- Distanziatore M0044
- 5- Molla 55189
- 6- Prolunga M0041
- 7- Pistone 93058
- 8- Molla 55223
- 9- Guarnizione 55133

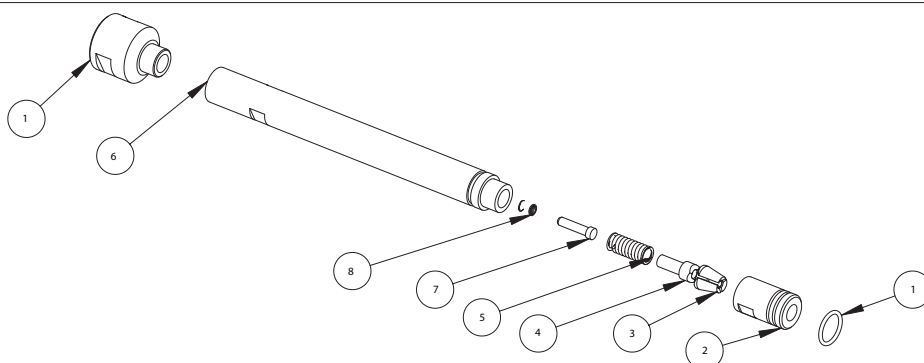

Svitare 2 utilizzando le chiavi di serraggio.

Sostituire i morsi 3 e poi, posizionarli da 3 a 120 °.

Posizionare successivamente 4,5,7 e 8. Poi avvitare 6 usando le chiavi (stringere bene).

Estrazione di un rivetto auto-perforante: (vedi capitolo precedente)

KIT 4

POSA DI RIVETTO ANGOLARE Ø 9.8

Ordine del montaggio del kit 4:

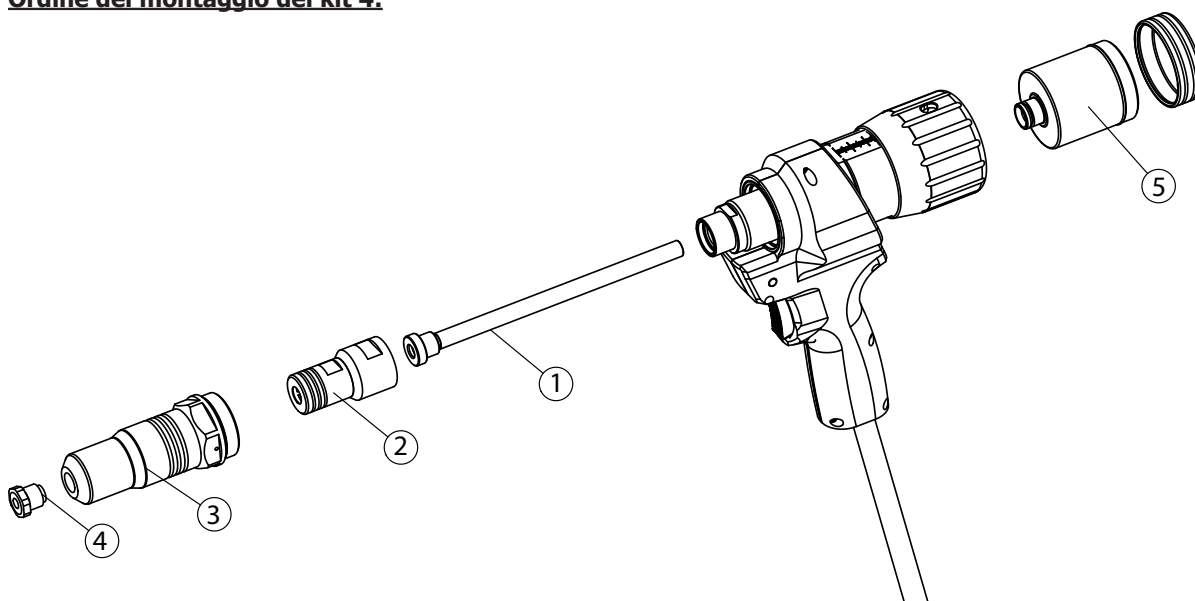

- 1- Mettere l'ugello 1
- 2- Avvitare il supporto morsi 2 con le 2 chiavi di serraggio (stringere bene)
- 3- Avvitare il supporto ugello 3 con le 2 chiavi di serraggio
- 4- Avvitare l'ugello Ø6 rif : 066052.
- 5- Infilare il recipiente di recupero 5.



Per facilitare il posizionamento degli ugelli:

- 1- Posizionare un rivetto nell'ugello.
- 2- Inserire il rivetto con l'ugello nel supporto montato.
- 3- Stringere l'ugello con una chiave di serraggio.



Posa di un rivetto angolare:

Dopo aver montato l'ugello corretto, posizionare il rivetto fino all'arresto dell'ugello

Posizionare il rivetto attraverso il foro delle lamiere da rivettare e premere il grilletto della rivettatrice secondo il modello sottostante :

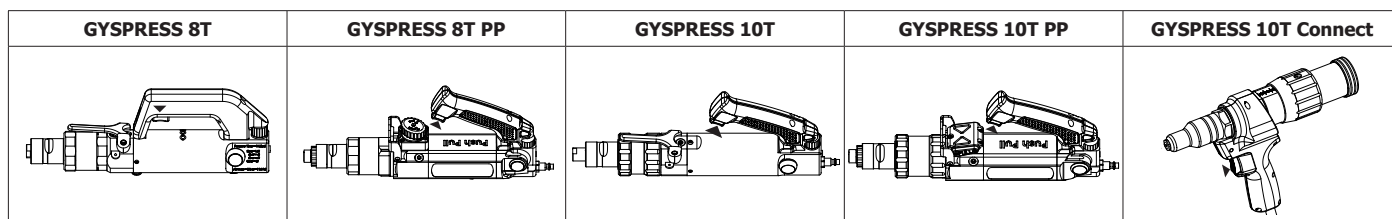

Una volta che il rivetto è scattato, rilascia il grilletto. Per rivettatrici 8T e 10T premere il grilletto come in seguito.

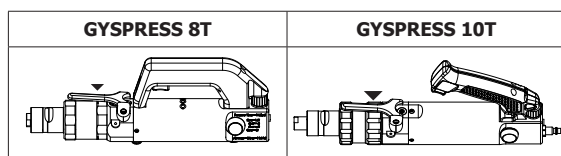

Quando si inclina l'adattatore all'indietro, i gambi dei rivetti cadono nel recipiente di raccolta.
Sporgendosi in avanti, le aste escono dall'ugello.

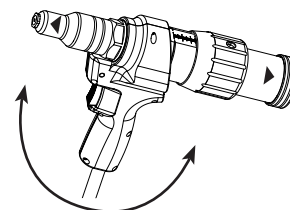

Recupero delle aste:

Per raccogliere le aste, tirare verso l'alto il coperchio del recipiente.
Una volta raccolte le aste, riposizionare il coperchio finché non scatta.

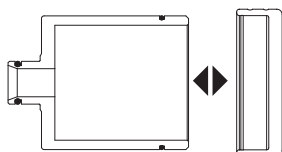

- 1- Recipiente M0077
- 2- Coperchio M0078
- 3- Anello toroidale 55262
- 4- Anello toroidale 55121

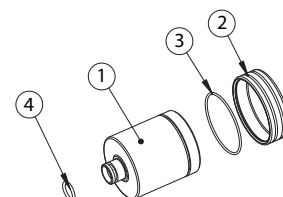

Sostituzione dei morsi:

Svitare utilizzando le chiavi di serraggio.
Sostituire i morsi 2 e poi, posizzionarli da 3 a 120 °.
Posizionare 4 poi 5 e poi avvitare 1 usando le chiavi (stringere bene).



- 1- Collemento con morsi M0042
- 2- Morsi 51522
- 3- Cono morsi M0043
- 4- Distanziatore M0044
- 5- Molla 55189

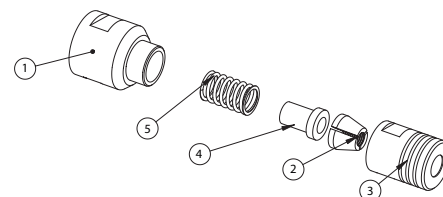

OMSCHRIJVING

De adapter voor blindklinknagels kan worden gebruikt met de ponsnageltangen GYSPRESS 8T/10T en GYSPRESS 8T PUSH PULL. De klinkkracht is 24 kN. U kunt blindklinknagels met een diameter van 4.0 tot 7.8 mm voor aluminium, en van 4.0 tot 6.4 mm in staal aanbrengen. U kunt tevens krimpmoeren en bouten aanbrengen.

VEILIGHEIDSINSTRUCTIES



- De adapter 50 KN mag niet gebruikt worden voor iets anders als het aanbrengen van blindklinknagels, krimpmoeren of bouten.
- Het dragen van een veiligheidsbril, een gehoorbescherming en veiligheidshandschoenen is verplicht. Richt nooit de neus van het apparaat naar uzelf of naar anderen.
- Overschrijd nooit de maximale pneumatische druk van 7 bar.
- Gebruik altijd blindklinknagels, volgens de bijbehorende specificaties.
- Plaats het mondstuk dat past bij de afmeting van de klinknagel. Forceer nooit bij het inbrengen van de klinknagel. Gebruik nooit een mondstuk dat groter is dan het uiteinde van de klinknagel.
- Controleer of de te verbinden onderdelen correct aan elkaar geklemd zijn.
- Houd de klinknageltang goed vast totdat de klinknagel bevestigd is. Als dit niet het geval is, laat dan de trekker los en druk deze weer in,
- Koppel altijd het apparaat van de netspanning af na gebruik, en wanneer u mondstukken wisselt.
- Bewaar deze handleiding zorgvuldig. Neem contact met ons op indien u de handleiding niet meer heeft.

OMGEVING

Dit apparaat mag uitsluitend gebruikt worden voor het uitvoeren van blindklinkwerkzaamheden, en alleen volgens de in de handleiding en/of op het typeplaatje vermelde instructies. De veiligheidsvoorschriften moeten altijd gerespecteerd worden. In geval van onjuist of gevaarlijk gebruik van dit materiaal kan de fabrikant niet aansprakelijk worden gesteld.

De installatie mag alleen worden gebruikt en bewaard in een stof- en zuurvrije ruimte, en in afwezigheid van ontvlambaar gas of andere corrosieve substanties. Zorg voor voldoende ventilatie tijdens het gebruik van deze apparatuur.

Gebruikstemperatuur :

Gebruik tussen -10 en +40°C (+14 en +104°F).

Opslag tussen -20 en +55°C (-4 en 131°F).

Luchtvochtigheid :

Lager of gelijk aan 50% bij 40°C (104°F).

Lager of gelijk aan 90% bij 20°C (68°F).

Hoogte :

Tot 1000 m boven het niveau van de zeespiegel (3280 voet).

IN GEVAL VAN STORING

Wanneer het apparaat niet klinkt :

- Controleer of de moer waarmee u de slag instelt op de juiste waarde is ingesteld.
- Controleer of de gebruikte blindklinktang correct functioneert.
- Controleer of er geen olie lekt, of dat er geen lek is in het persluchtcircuit.

ONDERHOUDSINSTRUCTIES

- Houd het gereedschap altijd in goede staat. Controleer regelmatig de goede staat van de aansluitingen van de perslucht, de goede staat van de 50 kN adapter (de natuurlijke speling tussen het uiteinde van de klinknagel en het mondstuk).
- Als het apparaat lagere tijd niet gebruikt is, dient u direct in de slang een klein beetje (5ml) olie voor pneumatische apparatuur te gieten, en vervolgens het apparaat meerdere keren in werking te stellen (2 tot 3 keer) om zo de olie rondom de zuiger te verspreiden.
- Controle van het oliepeil : De adapter is een hydropneumatisch gereedschap, dat functioneert met perslucht en olie. Het is de olie in de cilinder die het apparaat z'n vermogen geeft. Als het oliepeil onvoldoende is, zal de blindklinktang aan vermogen verliezen. In geval van een olielek dient u de blindklinktang stop te zetten en deze terug te sturen naar de uw verkooppunt.
- Vervangen van de bits (zie p.59)

SAMENVATTING

Ponsnageltang	Vermogen
GYPESPRESS 8T	40 kN
GYPESPRESS 8T PP	40 kN
GYPESPRESS 10T	50 kN
GYPESPRESS 10T PP	50 kN
GYPESPRESS 10T Connect	50 kN

MONTAGE OP GYPESPRESS

GYPESPRESS 8T :

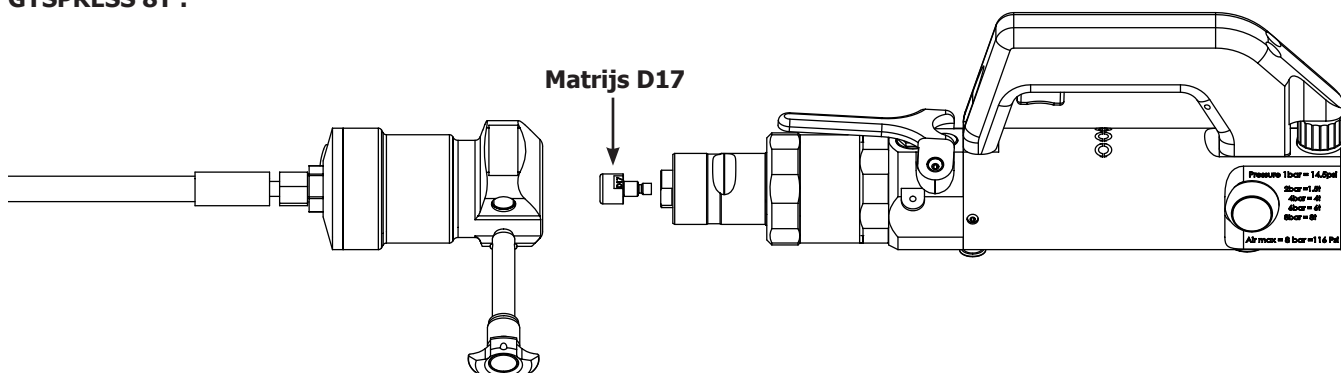

GYPESPRESS 8T PP :

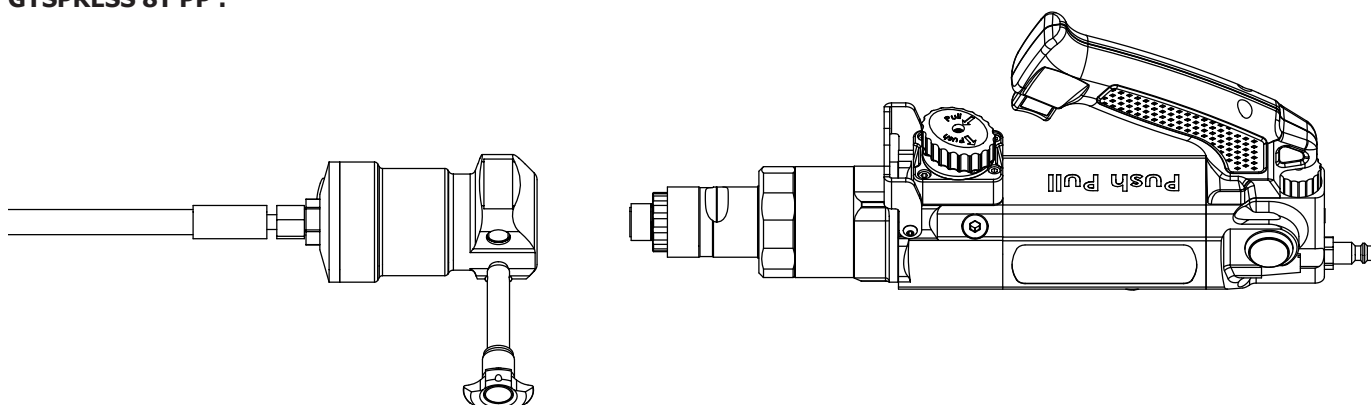

GYPESPRESS 10T :

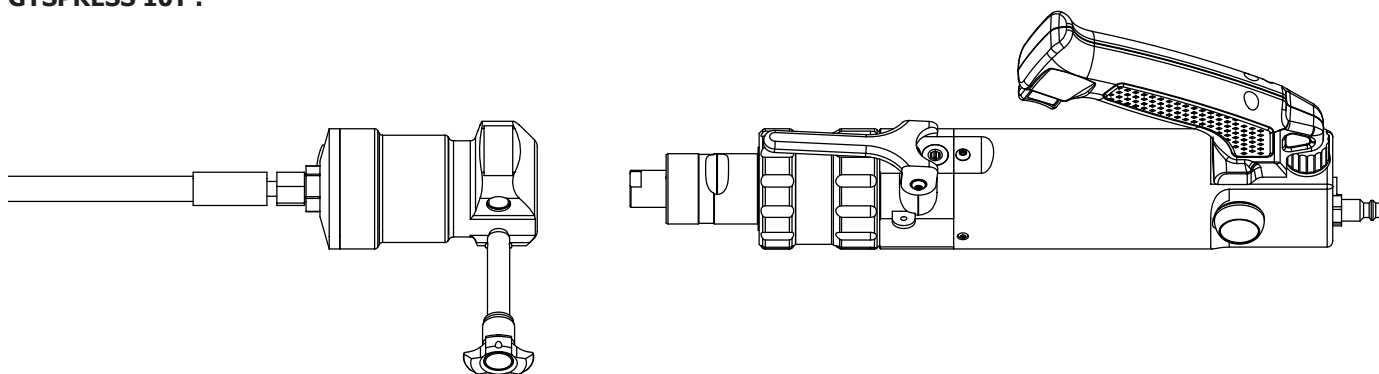

GYPESPRESS 10T Connect :

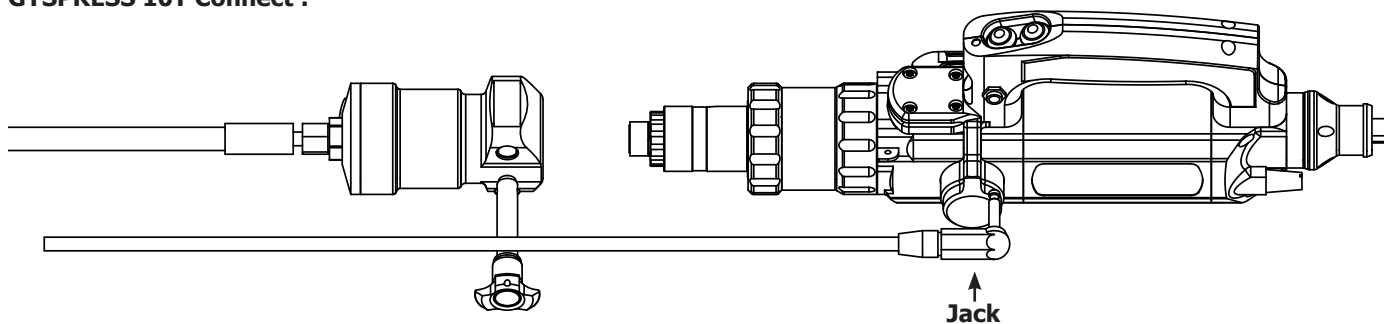

INSTELLEN KRACHT VAN DE ADAPTER

De trekkracht van de adapter hangt af van de kracht van de klinknageltang :

Correlatie-tabel met de kracht geleverd door de ponsnageltang en de luchtdruk aan de ingang van de ponsnageltang.

Luchtdruk	2 bar / 29 Psi		3 bar / 44 Psi		4 bar / 58 Psi		5 bar / 72 Psi		6 bar / 87 Psi		6,5 bar / 94 Psi		7 bar / 101 Psi		8 bar / 116 Psi	
	Ponsnagel-tang	Adapter	Ponsnagel-tang	Adapter	Ponsnagel-tang	Adapter	Ponsnagel-tang	Adapter	Ponsnagel-tang	Adapter	Ponsnagel-tang	Adapter	Ponsnagel-tang	Adapter	Ponsnagel-tang	Adapter
GYPESPRESS 8T	20 kN	10 kN	30 kN	15 kN	40 kN	20 kN	50 kN	25 kN	60 kN	30 kN	65 kN	32,5 kN	70 kN	35 kN	80 kN	40 kN
GYPESPRESS 8T PP	20 kN	10 kN	30 kN	15 kN	40 kN	20 kN	50 kN	25 kN	60 kN	30 kN	65 kN	32,5 kN	70 kN	35 kN	80 kN	40 kN
GYPESPRESS 10T	29 kN	19,5 kN	44 kN	22 kN	58 kN	29 kN	72 kN	36 kN	87 kN	43,5 kN	100 kN	50 kN	100 kN	50 kN	100 kN	50 kN
GYPESPRESS 10T PP	29 kN	19,5 kN	44 kN	22 kN	58 kN	29 kN	72 kN	36 kN	87 kN	43,5 kN	100 kN	50 kN	100 kN	50 kN	100 kN	50 kN
GYPESPRESS 10T Connect	29 kN	19,5 kN	44 kN	22 kN	58 kN	29 kN	72 kN	36 kN	87 kN	43,5 kN	100 kN	50 kN	100 kN	50 kN	100 kN	50 kN

INSTELLEN VAN DE SLAG

De slag van de adapter kan worden ingesteld van 0 tot 25 mm.
Deze kan worden ingesteld met behulp van de draaiknop A.
Schroef deze helemaal door voor 0 slag.
Schroef deze volledig los voor een slag van 25 mm.

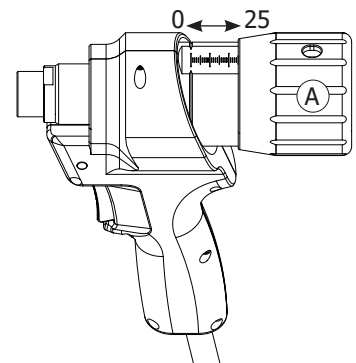

VERSCHILLENDE KITS OP DE ADAPTER

Kit 1 :
Aanbrengen van blindklinknagels voor pinnen met een diameter tot 5 mm + verwijderen van van self-piercing rivets.

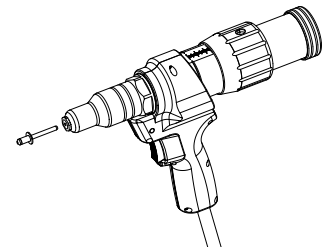

Kit 2 :
Aanbrengen van krimpmoeren en bouten M5 tot M14.

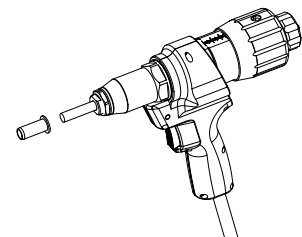

Kit 3 :
Verlengstuk voor het aanbrengen van blindklinknagels met een diameter tot 5 mm + verwijderen van self piercing rivets.

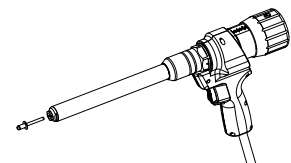

Kit 4 :
Aanbrengen van blindklinknagels \varnothing 9.8 mm.

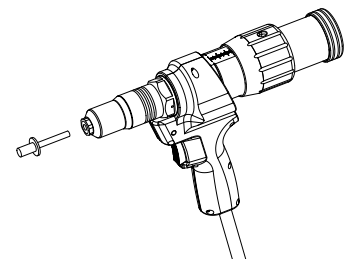

KIT 1

AANBRENGEN VAN BLINDKLINKNAGELS VOOR EEN DIAMETER TOT 5MM + VERWIJDEREN VAN SELF-PIERCING RIVETS.

Volgorde assemblage kit 1 :

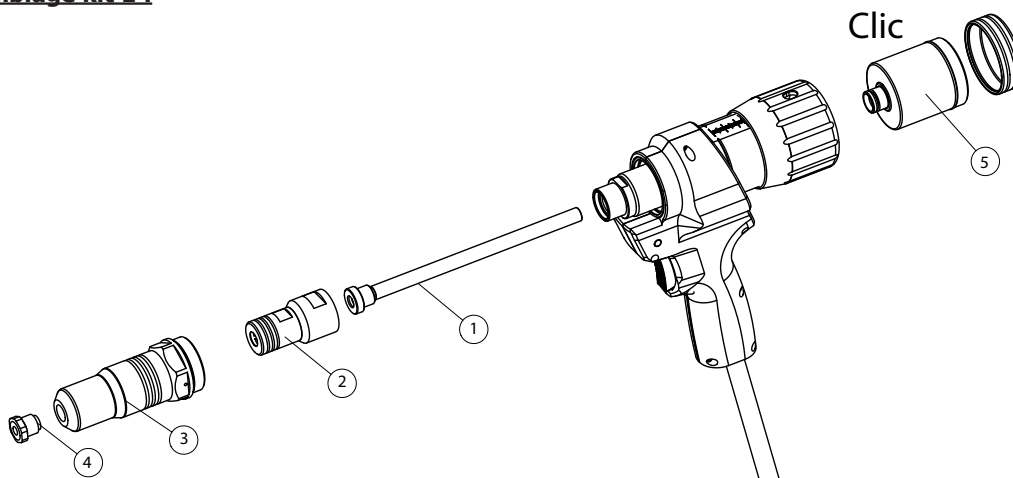

- 1- Plaats de sproeikop
- 2 - Schroef de houder voor de bits 2 vast met de 2 sleutels (goed aandraaien)
- 3- Schroef de houder voor het mondstuk 3 vast met de 2 sleutels
- 4 - Schroef één van de mondstukken op de te plaatsen klinknagel.

- Ø3.2 art. code : 065994
- Ø3.5 art. code : 066007
- Ø4.0 art. code : 066014
- Ø4.5 art. code : 066021
- Ø5.0 art. code : 066038

Om het plaatsen van de mondstukken eenvoudiger te maken :

- 1- Plaats een klinknagel in het mondstuk.
- 2- Plaats de rivet met het mondstuk in de gemonteerde houder.
- 3- Draai het mondstuk aan met de moersleutel.

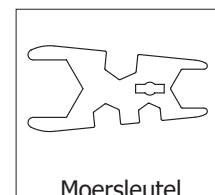

- 5- Plaats de houder voor het opvangen van rivets.

Plaatsen van een blindklinknagel :

Nadat u het juiste mondstuk heeft geplaatst, plaatst u de klinknagel in het mondstuk, totdat u niet verder kunt 

Plaats de klinknagel door de gaten van het plaatwerk en druk op de trekker van de klinknageltang. Zie het voorbeeld hieronder :

GYSPRESS 8T	GYSPRESS 8T PP	GYSPRESS 10T	GYSPRESS 10T PP	GYSPRESS 10T Connect

Wanneer de klinknagel is aangebracht, kunt u de trekker loslaten. Voor de ponsnageltangen 8T en 10T drukt u op de trekker hieronder.

GYSPRESS 8T	GYSPRESS 10T

Wanneer u de adapter naar achteren overhelt, zullen de resten van de klinknagel in het opvangreservoir vallen.
Wanneer u het nu naar voren helt, zullen de pinnen via het mondstuk naar buiten komen.

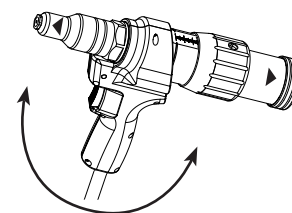

Opvangen van de pinnen :

Trek aan de deksel van het reservoir om de pinnen weg te nemen.
Nadat u de pinnen heeft gepakt kunt u het deksel weer terugplaatsen totdat u een klik hoort.

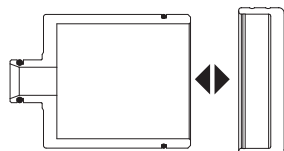

- | | |
|--------------|-------|
| 1- Reservoir | M0077 |
| 2- Deksel | M0078 |
| 3- O-ring | 55262 |
| 4- O-ring | 55121 |

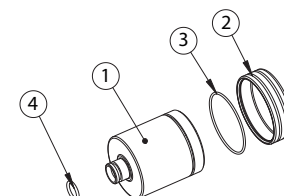

Vervangen van de bits :

Schroef los met behulp van de moersleutels.
Vervang de bits 2, en plaats ze vervolgens, in 3 bij 120°.
Plaats 4 en vervolgens 5 en schroef dan 1 met behulp van de sleutels (goed vastdraaien).

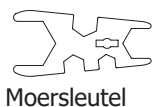

Moersleutel

- | | |
|---------------------------|-------|
| 1- Verbinding kegel bit | M0042 |
| 2- Bit (art. code 058446) | 51522 |
| 3- Kegel bit | M0043 |
| 4- Spreider | M0044 |
| 5- Veer | 55189 |

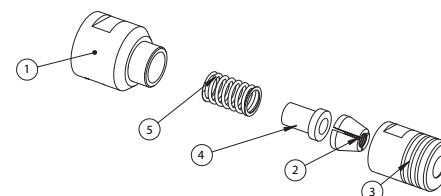

Extractie self piercing rivets :

Op de kit kan een speciaal mondstuk voor het verwijderen van self-piercing rivets geplaatst worden via de las van een pin op de rivet (art. code 066151).

Monteren van het mondstuk :

Monteer het extractie-mondstuk 066151 op de houder voor het mondstuk.

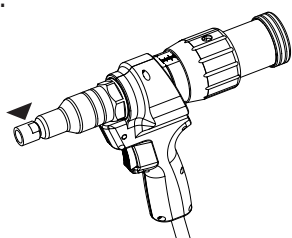

Stel de borgmoer op 15mm.

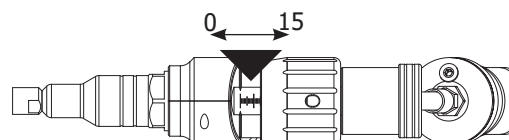

Stappen extractie :

1 - Lassen van de extractie-pin :
Materiaal : ARC PULL 350 062191 + ARC PULL RIVET BOX 064584

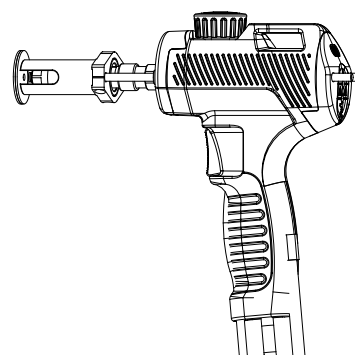
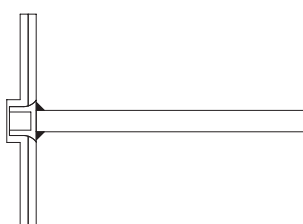

2- Breng de extractie-pin van de rivet in in het pistool tot deze niet verder kan, het mondstuk is in contact met het plaatwerk :

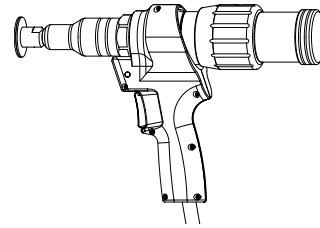
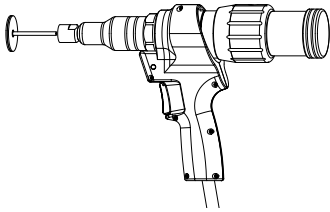

3- Activeer de adapter volgens de modellen hieronder :

GYPRESS 8T	GYPRESS 8T PP	GYPRESS 10T	GYPRESS 10T PP	GYPRESS 10T Connect

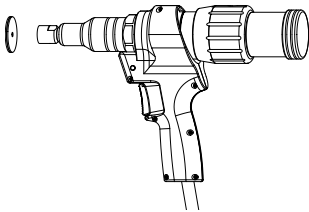

Wanneer de rivet uit het plaatwerk is verwijderd, kunt u de trekker loslaten. Voor de klinknageltangen 8T en 10T drukt u op de trekker hieronder.

GYPRESS 8T	GYPRESS 10T

De rivet en de pin komen er aan de voorkant uit :

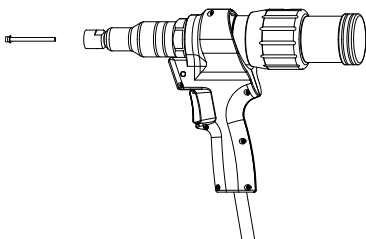

KIT 2

AANBRENGEN VAN KRIMPMOEREN EN BOUTEN M5 EN M14.

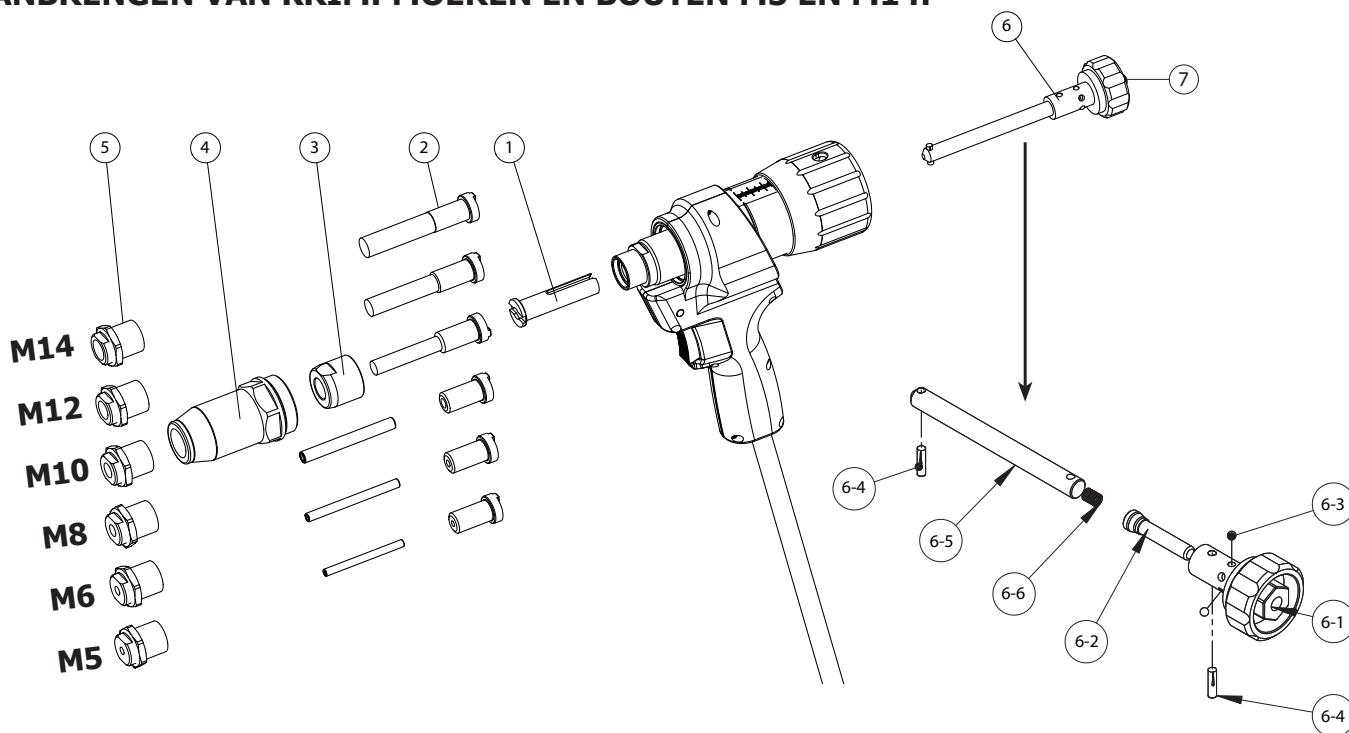

VOLGORDE ASSEMBLAGE KIT 2 :

- 1- Plaats 1
- 2 Plaats de schroef die geschikt is voor de moer of de bout (M5, M6, M8, M10, M12, M14)
- 3-Schroef de krimpmoer 3 met de 2 moersleutels (goed aandraaien)
- 4- Schroef de houder van het mondstuk 4
- 5- Visser het mondstuk 5 geschikt voor de krimpmoer of de bout (M5, M6, M8, M10, M12, M14)
- 6- Positioneer het draaiwiel op 6 (druk op de knop 7 om deze in te brengen)

Om het draaiwiel te verwijderen drukt u op knop 7 en trekt u aan het wieltje

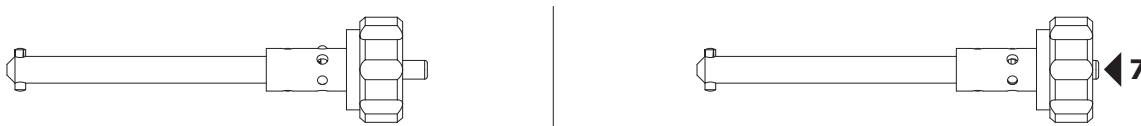

Koppel schroef en mondstuk, afhankelijk van het te plaatsen element.

Krimpmoer M14		Mondstuk M14		Pin M14
Krimpmoer M12		Mondstuk M12		Pin M12
Krimpmoer M10		Mondstuk M10		Pin M10
Krimpmoer M8		Mondstuk M8		Pin M8 Schroef M8

Krimpmoer M6		Mondstuk M6	
Krimpmoer M5		Mondstuk M5	
Bout M8		Mondstuk M8	
Bout M6		Mondstuk M6	
Bout M5		Mondstuk M5	

Aanbrengen van een krimpmoer :

			U kunt op twee manieren krimpmoeren aanbrengen :
1.	2. Schroef de krimpmoer ten minste tot het einde van de pin.	3. Schroef het mondstuk los tegen de insert en draai de krimpmoer aan.	4. Instellen voor het aanbrengen van krimpmoeren.

1 / Aanbrengen met druk

De benodigde kracht is afhankelijk van de afmeting van de krimpmoer.

Indicatieve aanwijzingen voor het aanbrengen van krimpmoeren (varieert en is afhankelijk van de constructeurs).

Aanbevolen kracht, per afmeting

Ø	Materiaal	Krach kN	Correspondentie klinknageltangen 8T		Correspondentie klinknageltangen 10T	
			Krach kN	Druk bar	Krach kN	Druk bar
M5	staal	8	16	1.6	16	1.1
M6	staal	12	24	2.4	24	1.6
M8	staal	18	36	3.6	36	2.5
M10	staal	21	42	4.2	42	3
M12	staal	23	46	4.6	46	3.2
M14	staal	50	-	-	100	6.5
M5	alu	3,8	7.6	0.8	7.6	0.5
M6	alu	5,5	11	1.1	11	0.75
M8	alu	10	20	2.0	20	1.5
M10	alu	12	24	2.4	24	1.6
M12	alu	15	30	3.0	30	2.0

Voor het aanbrengen onder druk kan de slag van de adapter op 25 mm (maxi) ingesteld worden.

Het instellen van de kracht wordt gedaan met het klinknagelapparaat. (instellen met de knop en aflezen van de druk).

1.1 / Opties

Aflesen van de manometer.

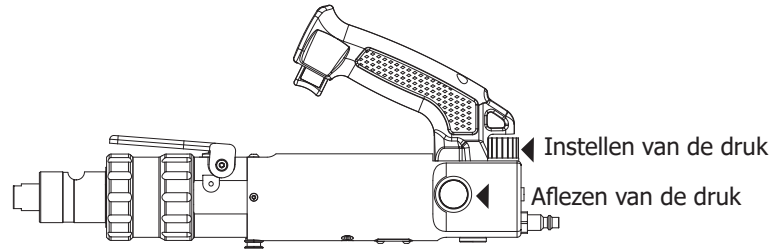

Aflesen op de krachtsensor
(preciezer) de beste oplossing

Aflesen van de
kracht

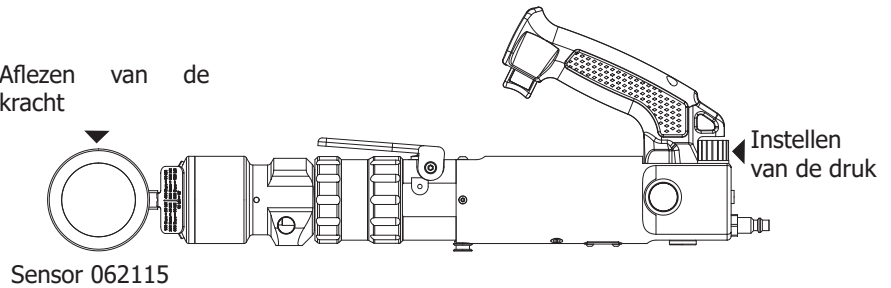

1.2 / Voorbeeld

Krimpmoer M10 staal, aan te brengen met een 10T ponsnageltang.

Instellen van de slag over 25 mm.

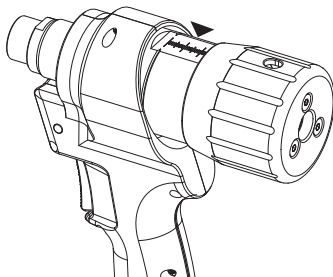

Instellen van de ponsnageltang met sensor over 210 bar, dit komt overeen met 42 kN.

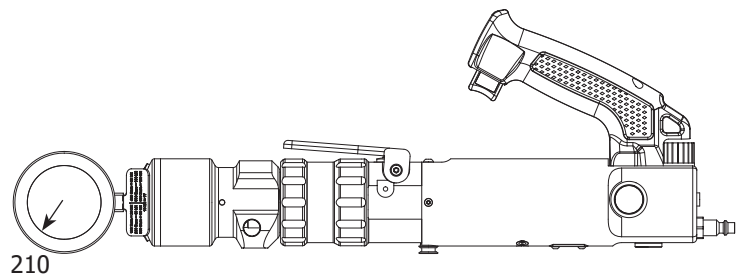

of

Instellen van de ponsnageltang met manometer 3
bar, komt overeen met 42 kN.

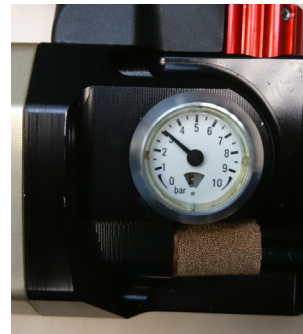

- Druk op de bediening van de ponsnageltang, en wacht tot deze blokkeert.
- Laat de trekker los en controleer of de insert correct geplaatst is.
- Als de krimpmoer niet goed genoeg aangedraaid lijkt, verhoog dan een beetje de kracht van de ponsnageltang.
- Om de trekpin van de krimpmoer terug te trekken kunt u de achterste draaiknop lossen schroeven.

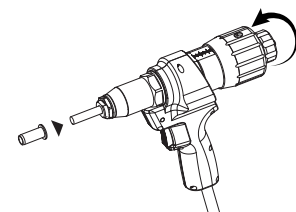

2/ Aanbrengen met slag

1. Neem de maat op van de binnenkant van de moer (A)
2. Neem de maat van de dikte van de kraag (B)
3. Meet de dikte van het plaatwerk waarop de moer met worden aangebracht (C)
4. Stel op de adapter het verkregen resultaat (D) in, met behulp van de formule :

$$D = A - B - C$$

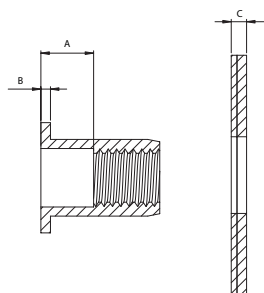
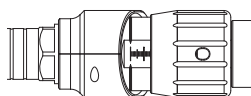

2.1 / Voorbeeld :

Krimpmoer M12 / Dikte plaatwerk 2 mm

1. Neem de maat op van de binnenkant van de krimpmoer (A) - 10.5mm
2. Neem de maat van de dikte van de kraag (B) = 2mm
3. Neem de maat van de dikte van het plaatwerk (C) = 2mm
4. Stel de adapter af op het verkregen resultaat

$$D = 10.5 - 2 - 2 = 6.5 \text{ mm}$$

$$D = 10.5 - 2 - 2 = 6.5 \text{ mm}$$

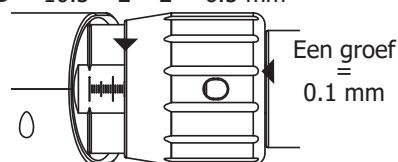

Voor een zo nauwkeurig mogelijke afstelling kunt u gebruik maken van de gradatie (in mm) en de groeven op de draaiknop.

Eén draai met de draaiknop komt overeen met 1.5mm slag, en er zitten 15 groeven op de moer.

5. druk op de bediening van de ponsnageltang en wacht tot deze blokkeert.

6. Laat de trekker los en controleer of de krimpmoer correct geplaatst is.

7. Voor het terugtrekken van de trekpin van de krimpmoer kunt u de achterste draaiknop losser schroeven.

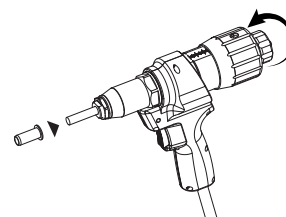

Een onjuiste instelling van het apparaat kan het onjuist aandraaien van de krimpmoeren veroorzaken.

Het instellen van slag is essentieel voor het bevestigen van de krimpmoer.

Een excessieve slag kan het materiaal doen afbreken, terwijl een te lage slag de stabiliteit van de krimpmoer niet garandeert.

Het is beter om stapje voor stapje de slag te verhogen.

3 / Aanbrengen van bouten :

Voor het aanbrengen van bouten is het niet mogelijk een meting te doen.

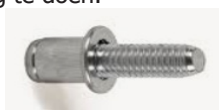

Het is beter om stapje voor stapje de slag te verhogen.

KIT 3

IVERLENGSTUK VOOR HET AANBRENGEN VAN BLINDKLINKNAGELS MET EEN DIAMETER TOT 5 MM + VERWIJDEREN VAN SELF PIERCING RIVETS.

Volgorde assemblage kit 3 :

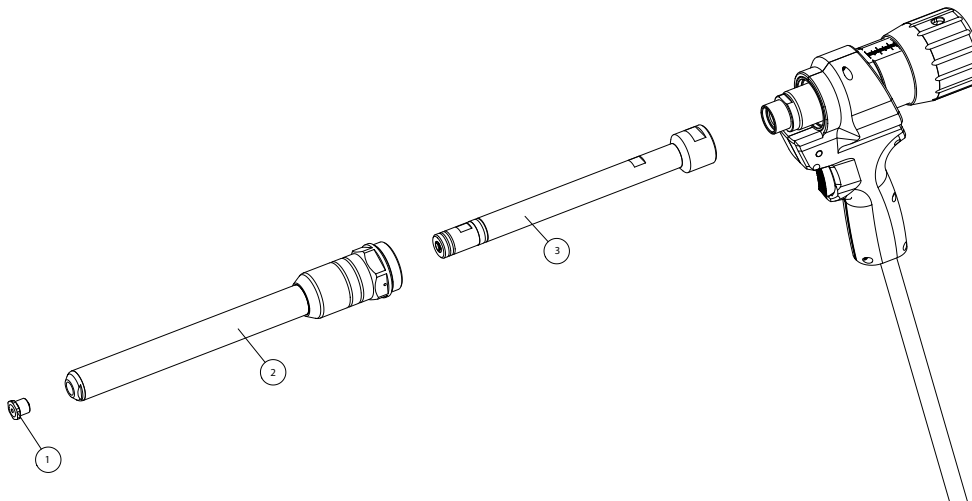

Bij gebruik van de kit is het niet nodig een reservoir voor het opvangen van pinnen te gebruiken. De pinnen komen, nadat ze afgebroken zijn, aan de voorkant uit het apparaat.

1. Schroef de houder met bit 3 met de 2 moersleutels vast (goed vastdraaien)
2. Schroef de houder van het mondstuk 2 met de 2 moersleutels vast
3. Schroef één van de mondstukken op (meegeleverd met de basiskit)

- Ø3.2 art. code : 065994
- Ø3.5 art. code : 066007
- Ø4.0 art. code : 066014
- Ø4.5 art. code : 066021
- Ø5.0 art. code : 066038

Om het plaatsen van de mondstukken eenvoudiger te maken :

- 1- Plaats een klinknagel in het mondstuk.
- 2- Plaats de rivet met het mondstuk in de gemonteerde houder.
- 3- Draai het mondstuk aan met de moersleutel.

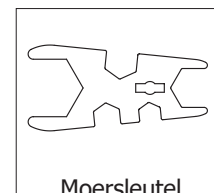

Plaatsen van een blindklinknagel :

Nadat u het juiste mondstuk heeft geplaatst, plaatst u de klinknagel in het mondstuk, totdat u niet verder kunt 

Plaats de klinknagel door de gaten van het plaatwerk en druk op de trekker van de klinknageltang. Zie het voorbeeld hieronder :

GYPRESS 8T	GYPRESS 8T PP	GYPRESS 10T	GYPRESS 10T PP	GYPRESS 10T Connect

Wanneer de klinknagel is aangebracht (u hoort een klak), kunt u de trekker loslaten. Voor de ponsnageltangen 8T en 10T drukt u op de trekker hieronder.

GYPRESS 8T	GYPRESS 10T

Wanneer u de adapter naar voren helt, zullen de pinnen door het mondstuk vallen.

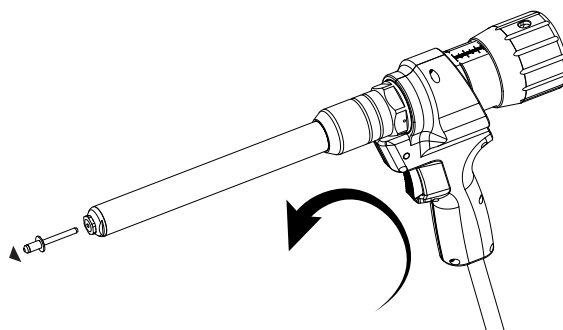

Vervangen van de bits :

- | | |
|-------------------------|--------|
| 1- Verbinding kegel bit | M0042 |
| 2- Kegeltje | M0043 |
| 3- Bit | 058446 |
| 4- Spreider | M0044 |
| 5- Veer | 55189 |
| 6- Verlengstuk | M0041 |
| 7- Druknop | 93058 |
| 8- Veer | 55223 |
| 9- Ringetje | 55133 |

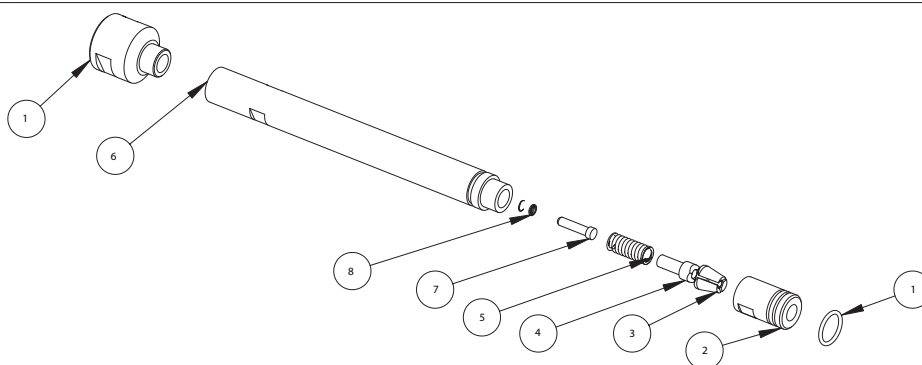

Schroef 2 los met behulp van de 2 moersleutels

Vervang de bits 3, en plaats ze vervolgens in 3 op 120°.

Plaats achtereenvolgens 4, 5, 7 en 8. Schroef vervolgens 6 met behulp van de sleutels (goed vastdraaien).

Verwijderen van self piercing rivets : (zie vorige hoofdstuk)

KIT 4

AANBRENGEN VAN BLINDKLINKNAGELS Ø 9.8

Volgorde assemblage kit 4 :

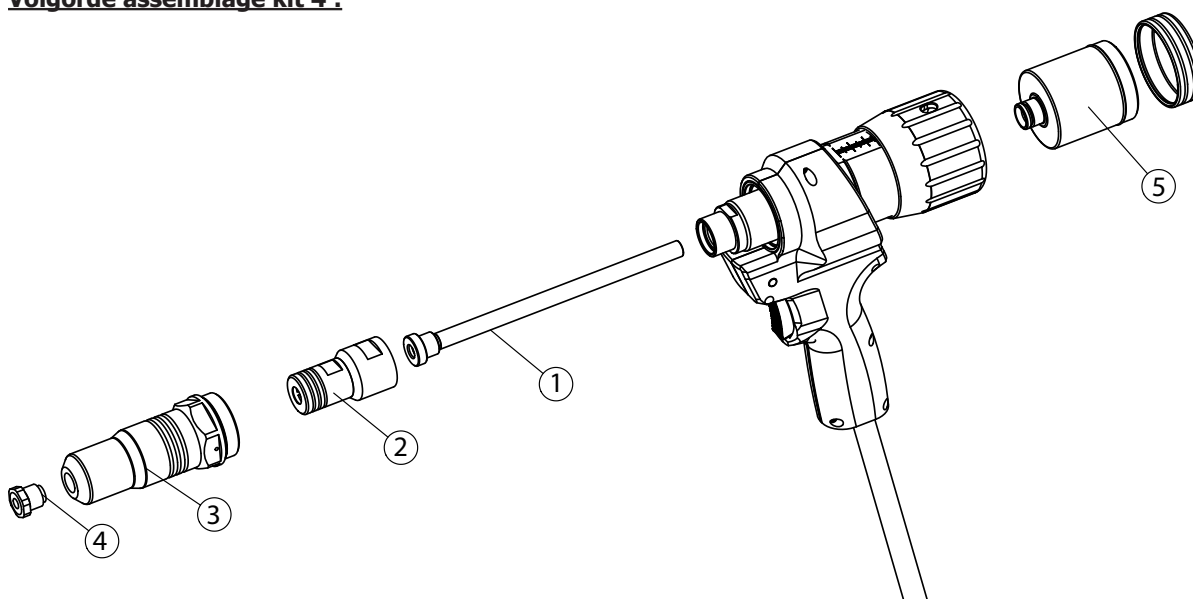

- 1 - Plaats de sproeikop 1.
- 2 - Schroef de houder van de bits 2 met de 2 moersleutels vast (goed vastdraaien).
- 3 - Schroef de houder van het mondstuk 3 met de 2 moersleutels vast.
- 4 - Schroef het mondstuk Ø6 art code 066052.
- 5 - Plaats het reservoir 5.

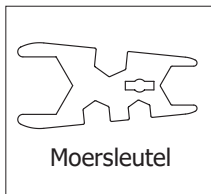

Om het plaatsen van de mondstukken eenvoudiger te maken :

- 1- Plaats een klinknagel in het mondstuk.
- 2- Plaats de rivet met het mondstuk in de gemonteerde houder.
- 3- Draai het mondstuk aan met de moersleutel.



Plaatsen van een blindklinknagel :

Nadat u het juiste mondstuk heeft geplaatst, plaatst u de klinknagel in het mondstuk, totdat u niet verder kunt



Plaats de klinknagel door de gaten van het plaatwerk en druk op de trekker van de klinknageltang. Zie het voorbeeld hieronder :

GYPRESS 8T	GYPRESS 8T PP	GYPRESS 10T	GYPRESS 10T PP	GYPRESS 10T Connect

Wanneer de klinknagel is aangebracht, kunt u de trekker loslaten. Voor de klinknageltangen 8T en 10T drukt u op de trekker hieronder.

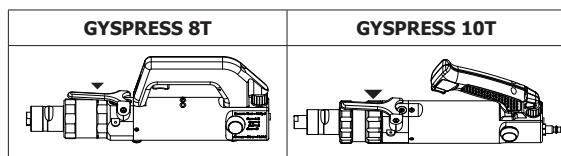

Wanneer u de adapter naar achteren overhelt, zullen de resten van de klinknagel in het opvangreservoir vallen.
Wanneer u het nu naar voren helt, zullen de pinnen via het mondstuk naar buiten komen.

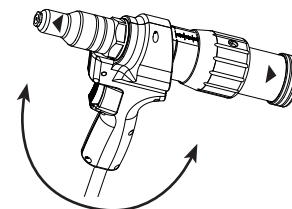

Opvangen van de pinnen :

Trek aan de deksel van het reservoir om de pinnen weg te nemen.
Nadat u de pinnen heeft gepakt kunt u het deksel weer terugplaatsen totdat u een klik hoort.

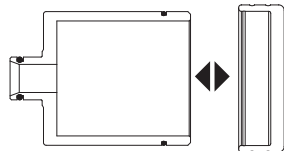

- | | |
|--------------|-------|
| 1- Reservoir | M0077 |
| 2- Deksel | M0078 |
| 3- O-ring | 55262 |
| 4- O-ring | 55121 |

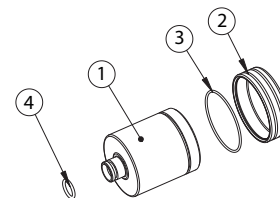

Vervangen van de bits :

Schroef los met behulp van de moersleutels.
Vervang de bits 2, en plaats ze vervolgens, in 3 bij 120°.
Plaats 4 en vervolgens 5 en schroef dan 1 met behulp van de sleutels (goed vastdraaien).

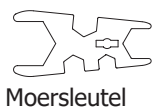



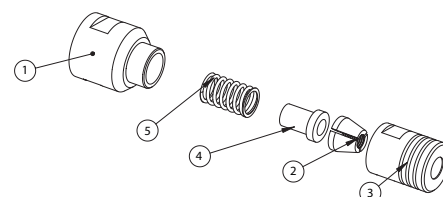



- | | |
|-------------------------|-------|
| 1- Verbinding kegel bit | M0042 |
| 2- Bit | 51522 |
| 3- Kegels bit | M0043 |
| 4- Spreider | M0044 |
| 5- Veer | 55189 |



50KN BLIND RIVET ADAPTER FOR 10T RIVETER

ICÔNES / SYMBOLS / ZEICHENERKLÄRUNG / SÍMBOLOS / SYMBOLEN /

	<ul style="list-style-type: none"> - Attention ! Risque d'écrasement des mains. - Warning ! Danger of crushing hands. - Achtung! Handverletzungen möglich. - ¡ATENCIÓN! Riesgo de aplastamiento de manos. 	<ul style="list-style-type: none"> - Внимание! Опасность прищемить руку. - Waarschuwing ! Gevaar van beknelling van handen. - Attenzione! Rischio di schiacciamento delle mani.
	<ul style="list-style-type: none"> - Attention ! Risque d'écrasement des doigts. - Warning ! Danger of crushing fingers. - Achtung! Quetschgefahr. - ¡ATENCIÓN! Riesgo de aplastamiento de dedos. 	<ul style="list-style-type: none"> - Внимание! Опасность прищемить пальцы. - Waarschuwing ! Gevaar van beknelling van vingers. - Attenzione! Rischio di schiacciamento delle dita.
	<ul style="list-style-type: none"> - Respecter les consignes générales. - Respect general rules. - Allgemeine Hinweise beachten. - Sigas las indicaciones generales. 	<ul style="list-style-type: none"> - Соблюдайте общие указания. - Respecteer algemene veiligheidsregels. - Rispettare le istruzioni generali.
	<ul style="list-style-type: none"> - Porter des gants. - Wear gloves. - Handschutz benutzen. - Lleve guantes. 	<ul style="list-style-type: none"> - Носите перчатки. - Draag beschermende werkhandschoenen. - Indossare dei guanti.
	<ul style="list-style-type: none"> - Porter un masque facial. - Wear a face mask. - Gesichtsschutz benutzen. - Lleve una máscara protectora. 	<ul style="list-style-type: none"> - Носите лицевую защитную маску. - Draag een veiligheidsmasker. - Indossare una maschera facciale.
	<ul style="list-style-type: none"> - Respecter le mode d'emploi. - Follow the user manual. - Betriebsanleitung beachten. - Siga el manual de instrucciones. 	<ul style="list-style-type: none"> - Соблюдайте инструкцию по эксплуатации. - Lees en volg de gebruiksaanwijzing op. - Rispettare le modalità di utilizzo.
	<ul style="list-style-type: none"> - Matériel conforme aux Directives européennes. La déclaration UE de conformité est disponible sur notre site (voir à la page de couverture). - Device complies with europeans directives, The EU declaration of conformity is available on our website (see cover page). - Gerät entspricht europäischen Richtlinien. Die Konformitätserklärung finden Sie auf unsere Webseite. - Aparato conforme a las directivas europeas. La declaración de conformidad UE está disponible en nuestra página web (dirección en la portada). - Устройство соответствует директивам Евросоюза. Декларация о соответствии доступна для просмотра на нашем сайте (ссылка на обложке). - Apparaat in overeenstemming met de Europese richtlijnen. De verklaring van overeenstemming is te downloaden op onze website (adres vermeld op de omslag). - Materiale in conformità alle Direttive europee. La dichiarazione di conformità è disponibile sul nostro sito (vedere sulla copertina). 	

SAS JBDC
 1, rue de la Croix des Landes
 CS 54159
 53941 SAINT-BERTHEVIN
 Cedex France